



KM-1620

KM-2020

PARTS LIST

Published in Jan. '04
842C9122
Revision 2

NOTE

1. Indicate parts number and machine model when placing an order.

eg.	Parts Number	Parts Name	Machine Model	Cycle	Quantity
	2C904010	FRONT RIGHT COVER	KM-1620	50Hz	1
	2FX04010	FRONT RIGHT COVER	KM-2020	50Hz	1

2. Service calls and freight will be charged separately.

3. Symbols in the "Parts Number" column.

- Parts with "⊙" indicates the spare parts and the parts without "⊙" can not be supplied.

- Parts with "." are component parts or sub-assemblies of the assembly appearing immediately above them.

eg.	Parts Number	Parts Name	Parts Number	Parts Name
	2C982010	SET, MK-410	•2C918010	BLADE CLEANING
			•2C918340	HOLDER CLAW

- Parts with ".•" are component parts or sub-assembly with "." appearing immediately above them.

eg.	Parts Number	Parts Name	Parts Number	Parts Name
	•2C993020	PARTS, MC-410, SP	••2C910040	GRID
			••2BZ02300	SPRING WIRE

4. See the last page of this parts list for the classification of the screws in the illustrations.

5. Items indicated by shaded areas () are supply parts and should be ordered through your Regional Office.

CONTENTS

FIG. 1	EXTERIOR COVERS	2	FIG. 10	FUSER UNIT	20
FIG. 2	FRAMES.....	4	FIG. 11	DRIVING & COOLING SECTION	22
FIG. 3	CASSETTE.....	6	FIG. 12	ELECTRICAL COMPONENTS	24
FIG. 4	CONVEYING SECTION	8	FIG. 13	OPERATION UNIT	26
FIG. 5	PAPER FEED SECTION	10	FIG. 14	ORIGINAL HOLDER	28
FIG. 6	BYPASS SECTION	12	FIG. 15	OPTION I(DU-410).....	30
FIG. 7	EXIT SECTION.....	14	FIG. 16	OPTION II.....	32
FIG. 8	SCANNER SECTION	16			
FIG. 9	IMAGING UNIT.....	18		• INDEX	34

FIG. 1 EXTERIOR COVERS

2C9-2/2FX

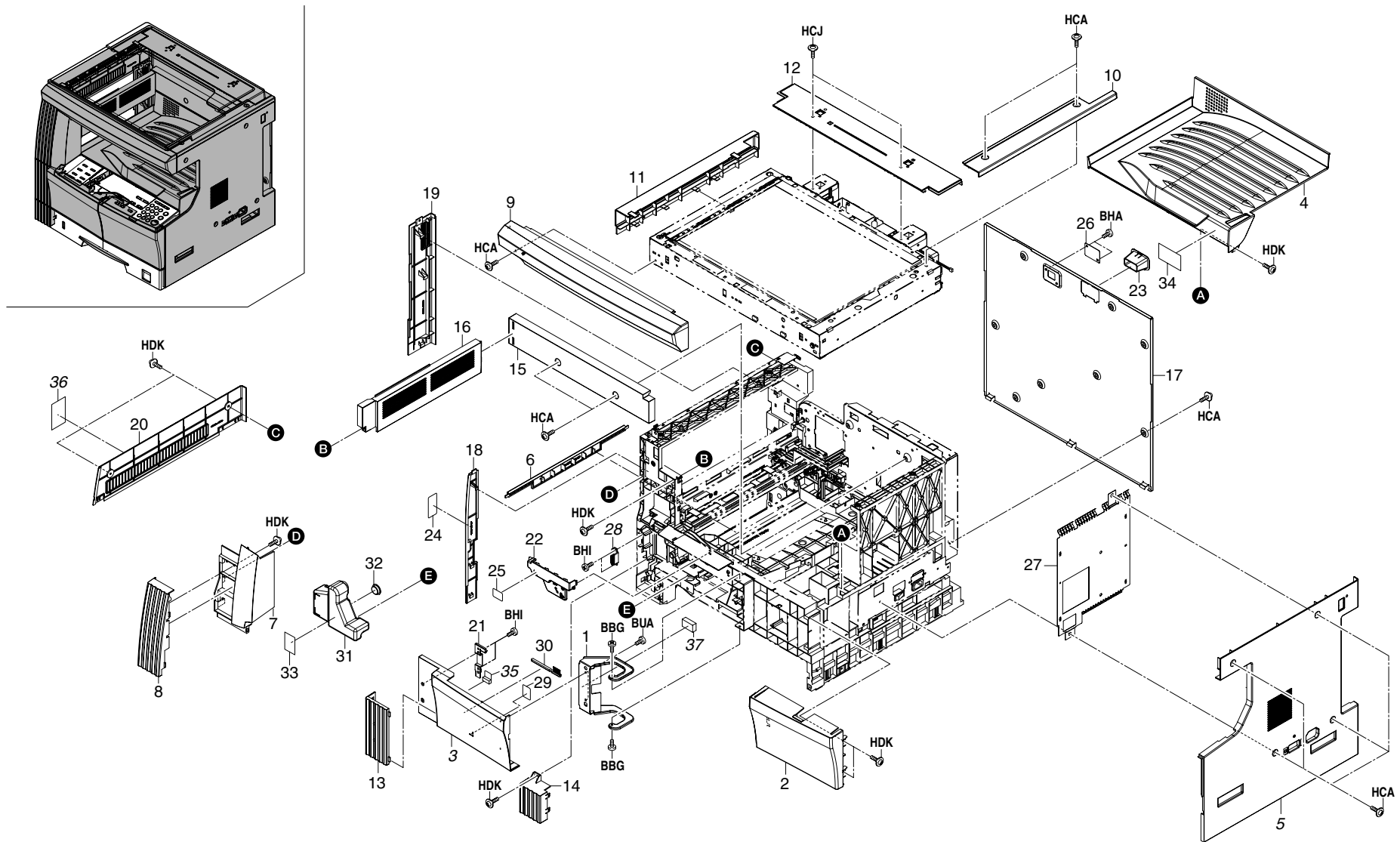

FIG. 1 EXTERIOR COVERS

2C9-2/2FX

SP	Ref. No	Part.No.	Description	Quality			
				110V	120V	230V	240V
	1	2C902140	HINGE FRONT COVER	1	1	1	1
⊙	2	2C904010	FRONT RIGHT COVER(KM-1620)	1	1	1	1
⊙	2	2FX04010	FRONT RIGHT COVER(KM-2020)		1	1	1
⊙	3	2C904470	FRONT LEFT COVER(K)	1	1	1	1
⊙	4	2C904030	TRAY EXIT (1/2)	1	1	1	1
⊙	5	2C904041	RIGHT COVER	1	1	1	1
⊙	6	2C904060	LEFT LOW COVER	1	1	1	1
⊙	7	2C904070	UPPER FRONT COVER	1	1	1	1
⊙	8	2C904080	FRONT SIDE COVER UP	1	1	1	1
⊙	9	2C904090	FRONT TOP COVER	1	1	1	1
⊙	10	2C904100	RIGHT TOP COVER	1	1	1	1
⊙	11	2C904110	LEFT TOP COVER	1	1	1	1
⊙	12	2C904120	REAR TOP COVER	1	1	1	1
⊙	13	2C904130	FRONT SIDE COVER MID	1	1	1	1
⊙	14	2C904140	FRONT SIDE COVER LOW	1	1	1	1
⊙	15	2C904150	INNER REAR COVER	1	1	1	1
⊙	16	2C904160	INNER LEFT COVER	1	1	1	1
⊙	17	2C904170	REAR COVER	1	1	1	1
⊙	18	2C904180	LEFT FRONT COVER	1	1	1	1
⊙	19	2C904190	LEFT REAR COVER	1	1	1	1
⊙	20	2C904200	LEFT MIDDLE COVER	1	1	1	1
	21	2C904290	PLATE FRONT COVER	1	1	1	1
⊙	22	2C904370	INNER FRONT COVER	1	1	1	1
	23	2C904410	COVER DSUB	1	1	1	1
⊙	24	2C905080	LABEL CONVEYING JAM	1	1	1	1
⊙	25	2C905100	LABEL RADIATION		1		
	26	2C912430	LID KMAS	1	1	1	1
	27	2C926130	SHIELD RIGHT COVER	1	1	1	1
	28	60804120	MAGNET CATCH	1	1	1	1
⊙	29	2BL05070	LABEL SEP CLEANING	1	1	1	1
	30	2BL16220	BRUSH CLEANER	1	1	1	1
	31	2C918150	TANK DISPOSAL	1	1	1	1
	32	2C918170	CAP TANK DISPOSAL	1	1	1	1
	33	2AV73580	LABEL, TONER DISPOSAL TANK HK	1	1	1	1
	34	2C905180	LABEL ERROR CODE J	1	1	1	1
⊙	35	2C904480	FILM FRONT COVER	1	1	1	1
	36	2C905220	LABEL LEFT COVER	1	1	1	1
⊙	37	2C904510	SPONGE COVER	1	1	1	1

- Parts with "*" are component parts or sub-assemblies of the assembly appearing immediately above them.
- Parts with "⊙" indicates the spare parts.

- Parts with "••" are component parts or sub-assembly with "•" appearing immediately above them.

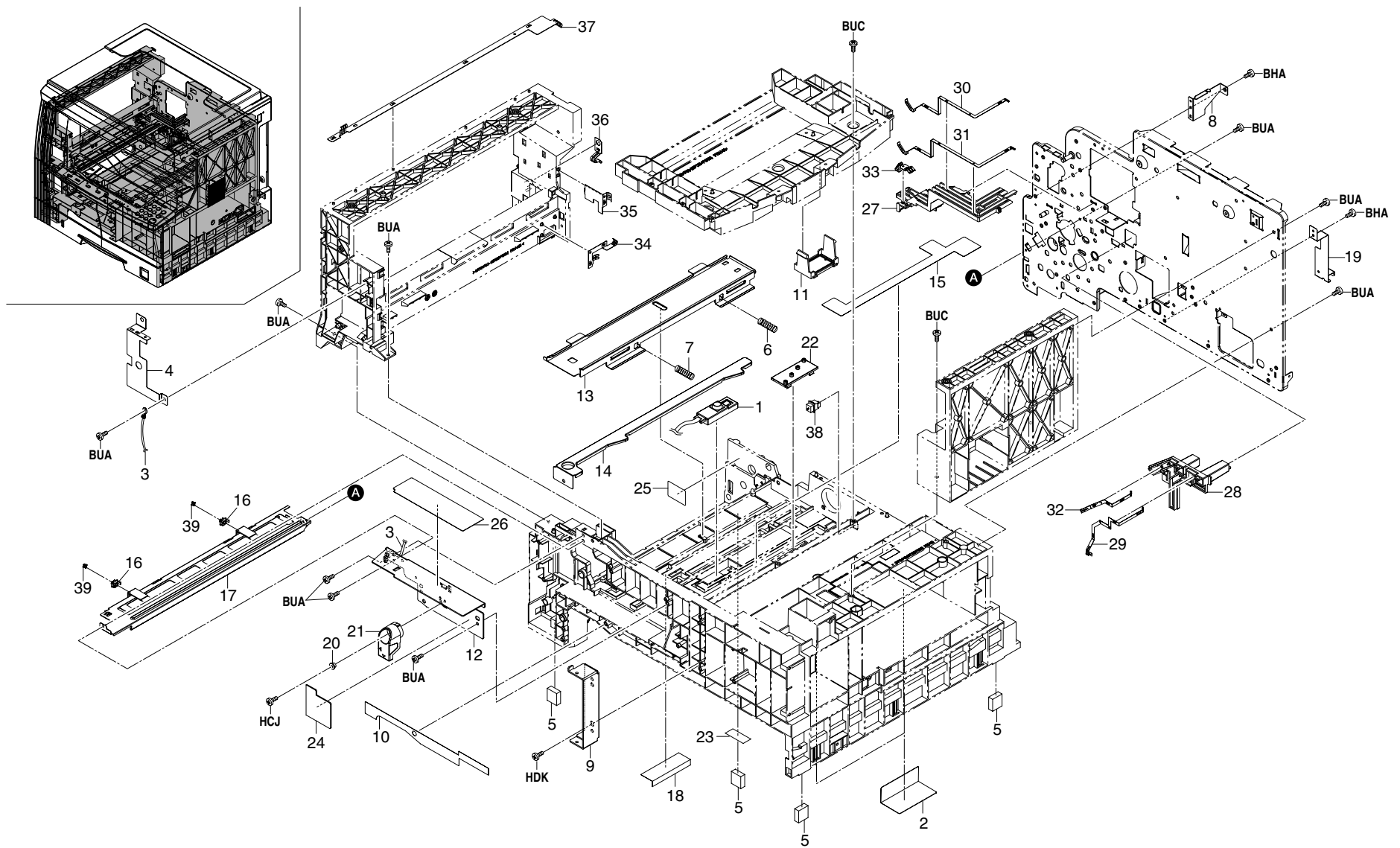

FIG. 2 FRAMES

2C9/2FX

SP	Ref. No	Part.No.	Description	Quality			
				110V	120V	230V	240V
⊙	1	2C901180	CONT SENSOR ASSY	1	1	1	1
	2	2C902230	FILM BASE L	2	2	2	2
	3	2C927790	WIRE UPPER LEFT	1	1	1	1
	4	2C926150	SHIELD UPPER LEFT B	1	1	1	1
	5	2C902070	BASE RUBBER	4	4	4	4
	6	2C902080	SPRING DEV PUSH	1	1	1	1
	7	2C902590	SPRING DEV PUSH F	1	1	1	1
	8	2C902100	MOUNT REAR COVER	1	1	1	1
	9	2C902110	MOUNT FRONT COVER	1	1	1	1
	10	2C902120	PANEL FRONT	1	1	1	1
	11	2C902130	MOUNT CONT PCB	1	1	1	1
	12	2C902150	MOUNT CONT LEVER	1	1	1	1
	13	2C902160	RAIL DLP	1	1	1	1
	14	2C902170	LEVER DEV PUSH	1	1	1	1
⊙	15	2C902180	FILM BASE	1	1	1	1
	16	2C902280	HOLDER PULLEY	2	2	2	2
	17	2C902200	RAIL CLEANING	1	1	1	1
	18	2C902240	FILM BASE B	1	1	1	1
	19	2C902260	GROUND PLATE FRAME	1	1	1	1
	20	2C902520	COLLAR LEVER CONT.	1	1	1	1
⊙	21	2C902540	LEVER LOCK CONT.	1	1	1	1
	22	2C902510	GUIDE A CONT.		1		
	22	2C902560	GUIDE B CONT.	1		1	1
	23	2C902270	SPACER BASE	1	1	1	1
	24	2C905070	LABEL CONT SET	1	1	1	1
	25	2C905110	LABEL DRUM CAUTION	1	1	1	1
	26	2C925190	SHEET OPERATION PCB	1	1	1	1
	27	2C926010	BASE TERMINAL TRANSFER	1	1	1	1
	28	2C926020	BASE TERMINAL MAIN	1	1	1	1
	29	2C926030	TERMINAL DLP	1	1	1	1
	30	2C926040	TERMINAL TRANSFER	1	1	1	1
	31	2C926050	TERMINAL SEPARATION	1	1	1	1
	32	2C926060	TERMINAL MAIN	1	1	1	1
	33	2C926080	GROUND PLATE CONVEYING	1	1	1	1
	34	2C926100	TERMINAL FUSER	1	1	1	1
	35	2C926110	GROUND PLATE EXIT	1	1	1	1
	36	2C926120	GROUND PLATE FUSER	1	1	1	1
	37	2C926140	SHIELD UPPER LEFT	1	1	1	1
⊙	38	2C927140	SWITCH CONTAINER	1	1	1	1
⊙	39	2A118370	PULLEY,DRUM SEPARATION	2	2	2	2

- Parts with "*" are component parts or sub-assemblies of the assembly appearing immediately above them.
- Parts with "⊙" indicates the spare parts.

- Parts with "••" are component parts or sub-assembly with "••" appearing immediately above them.

FIG. 3 CASSETTE

2C9-2/2FX

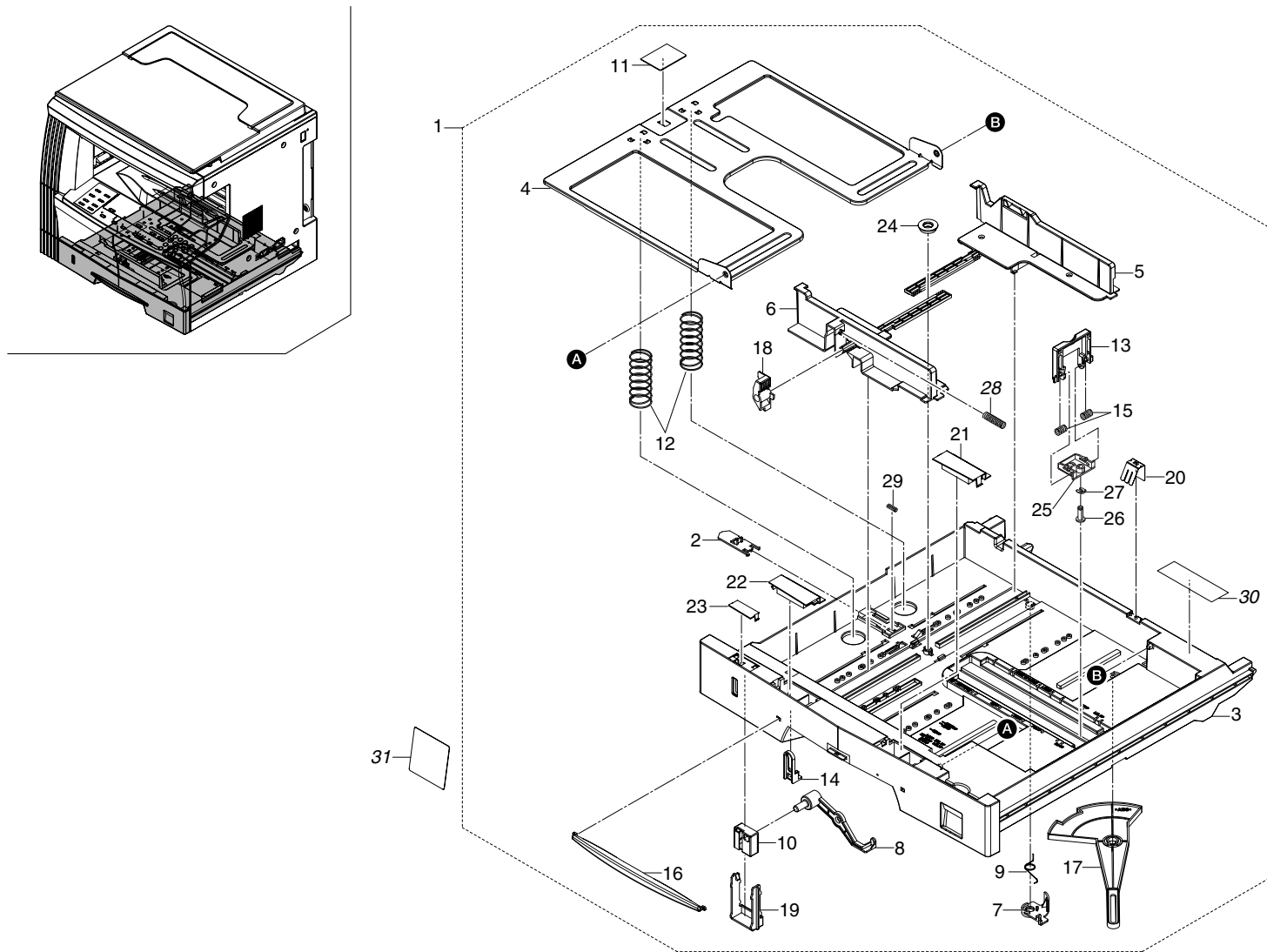

FIG. 3 CASSETTE

2C9-2/2FX

SP	Ref. No	Part.No.	Description	Quality			
				110V	120V	230V	240V
⊙	1	2C993010	PARTS,CT-410,SP	1	1	1	1
	2	•19507050	LEVER,CASSETTE BASE RELEASE	1	1	1	1
	3	•2C907010	CASSETTE	1	1	1	1
	4	•2C907020	BOTTOM CASSETTE	1	1	1	1
⊙	5	•2C907030	REAR CURSOR C	1	1	1	1
⊙	6	•2C907040	FRONT CURSOR C	1	1	1	1
	7	•2C907050	PLATE SIDE SW	1	1	1	1
	8	•2C907070	LEVER INDICATOR	1	1	1	1
⊙	9	•2C907090	SPRING SIDE SW	1	1	1	1
	10	•2C907110	MARKER INDICATOR	1	1	1	1
⊙	11	•2C907140	PAD CASSETTE	1	1	1	1
⊙	12	•2C907150	SPRING BOTTOM	2	2	2	2
⊙	13	•2C907190	RIGHT CURSOR A	1	1	1	1
	14	•2C907200	STOPPER ARM	1	1	1	1
	15	•2C907360	SPRING CURSOR R	2	2	2	2
⊙	16	•2C907370	MARKER CASSETTE	1	1	1	1
	17	•2C907380	TURN PLATE CASSETTE	1	1	1	1
⊙	18	•2C907390	LEVER CURSOR C	1	1	1	1
	19	•2C907490	STOPPER INDICATOR	1	1	1	1
	20	•2C907500	GROUND PLATE BOTTOM	1	1	1	1
	21	•2C907550	LID CASSETTE A	1	1	1	1
	22	•2C907560	LID CASSETTE B	1	1	1	1
	23	•2C907570	LID CASSETTE C	1	1	1	1
⊙	24	•34907141	GEAR 18,CASSETTE	1	1	1	1
⊙	25	•2C907590	HOLDER RIGHT CURSOR	1	1	1	1
⊙	26	•2C907600	PIN CURSOR C	1	1	1	1
⊙	27	•2A806250	RING STOPPER	1	1	1	1
⊙	28	•2C907620	SPRING LEVER F	1	1	1	1
⊙	29	•76508130	SPRING BELT GUIDE ROLLER	1	1	1	1
	30	•2C905200	LABEL CASSETTE LGR	1	1	1	1
⊙	31	2C905230	SHEET CASSETTE SIZE(C)	1	1	1	1
⊙	31	2C905240	SHEET CASSETTE SIZE(I)	1	1	1	1

- Parts with "•" are component parts or sub-assemblies of the assembly appearing immediately above them.
- Parts with "⊙" indicates the spare parts.

- Parts with "••" are component parts or sub-assembly with "•" appearing immediately above them.

FIG. 4 CONVEYING SECTION

2C9-2/2FX

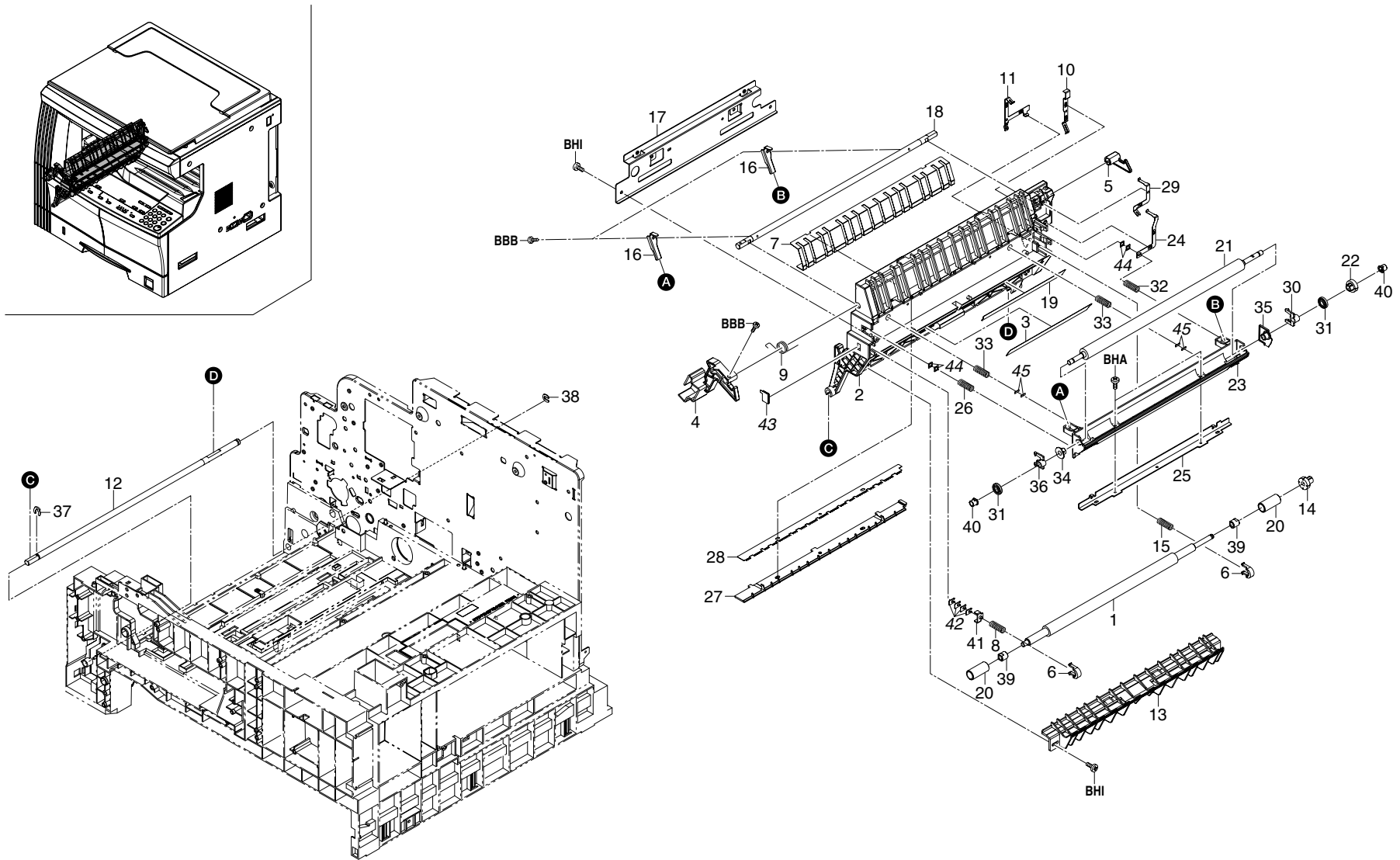

FIG. 4 CONVEYING SECTION

2C9-2/2FX

SP	Ref. No	Part.No.	Description	Quality			
				110V	120V	230V	240V
⊙	1	2C916020	ROLLER REGIST LEFT	1	1	1	1
	2	2C916030	BASE CONVEYING	1	1	1	1
⊙	3	2C916040	FILM REGIST GUIDE	1	1	1	1
⊙	4	2C916060	LEVER CONVEYING FRONT	1	1	1	1
⊙	5	2C916070	LEVER CONVEYING REAR	1	1	1	1
⊙	6	2C916080	STOPPER BUSH REG	2	2	2	2
	7	2C916090	GUIDE CONVEYING	1	1	1	1
	8	2C916100	SPRING REGIST F	1	1	1	1
	9	2C916120	SPRING CONVEYING BASE	1	1	1	1
	10	2C916130	GROUND PLATE REG	1	1	1	1
	11	2C916140	GROUND PLATE CONVEYING	1	1	1	1
	12	2C916160	SHAFT CONVEYING	1	1	1	1
	13	2C916170	GUIDE FEED A	1	1	1	1
⊙	14	2C916180	GEAR Z15 REGIST	1	1	1	1
	15	2C916190	SPRING REGIST R	1	1	1	1
	16	2C916200	LEVER TRANS GUIDE	2	2	2	2
	17	2C916220	REINFORCEMENT CONVEYING	1	1	1	1
	18	2C916230	SHAFT CONVEYING LEVER	1	1	1	1
	19	2C916240	FILM REGIST GUIDE R	1	1	1	1
	20	2C916250	COLLAR REGIST	2	2	2	2
⊙	21	2C917010	ROLLER TRANSFER	1	1	1	1
⊙	22	2C917020	GEAR TRANSFER	1	1	1	1
	23	2C917030	GUIDE LEFT TRANS FRONT	1	1	1	1
	24	2C917040	TERMINAL PLATE TRANS	1	1	1	1
	25	2C917050	REINFORCEMENT TRANS GUIDE	1	1	1	1
	26	2C917060	SPRING TRANS F	1	1	1	1
⊙	27	2C917070	HOUSING STA ELIMINATION	1	1	1	1
⊙	28	2C917080	PLATE STA ELIMINATION	1	1	1	1
	29	2C917090	TERMINAL STA ELIMINATION	1	1	1	1
⊙	30	2C917100	BUSH TRANSFER	1	1	1	1
⊙	31	2C917110	COLLAR TRANS	2	2	2	2
	32	2C917120	SPRING TRANS R	1	1	1	1
	33	2C917150	SPRING GUIDE TRANS	2	2	2	2
	34	2C917160	BUSH TRANS GUIDE F	1	1	1	1
	35	2C917170	BUSH TRANS GUIDE R	1	1	1	1
	36	2C917180	BUSH TRANS ROLL F	1	1	1	1
⊙	37	2BC06910	STOPPER 6	1	1	1	1
⊙	38	2BC06980	STOPPER 5	1	1	1	1
⊙	39	2C916260	BUSH REGIST	2	2	2	2
⊙	40	2BL17030	COLLAR TRANS ROLLER	2	2	2	2

- Parts with "*" are component parts or sub-assemblies of the assembly appearing immediately above them.
- Parts with "⊙" indicates the spare parts.

SP	Ref. No	Part.No.	Description	Quality			
				110V	120V	230V	240V
	41	2C916270	SPACER REG F	1	1	1	1
	42	2C916280	SPACER REG T0.5	4	4	4	4
	43	2C916290	FILM CONV BASE	1	1	1	1
	44	2C917200	SPACER TRANS ROLL	4	4	4	4
	45	2C917210	SPACER GUIDE LEFT TRANS	4	4	4	4

- Parts with "*" are component parts or sub-assembly with "*" appearing immediately above them.

FIG. 5 PAPER FEED SECTION

2C9-2/2FX

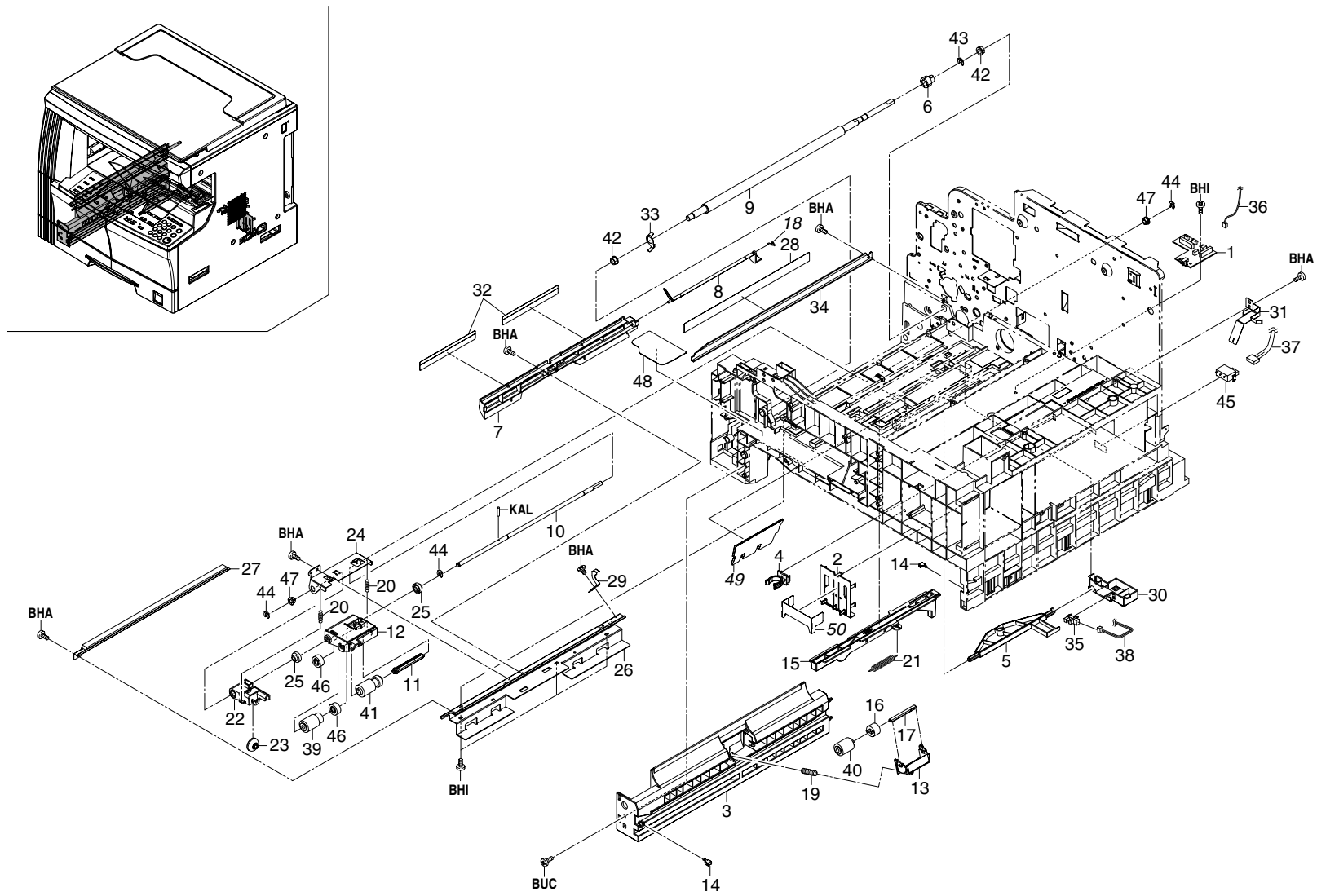

FIG. 5 PAPER FEED SECTION

2C9-2/2FX

SP	Ref. No	Part.No.	Description	Quality			
				110V	120V	230V	240V
⊙	1	2C901100	PCB CASSETTE ASSY	1	1	1	1
	2	2C907060	PLATE SIZE DETECTION	1	1	1	1
	3	2C907080	LEFT RAIL CASSETTE	1	1	1	1
⊙	4	2C907100	STOPPER CASSETTE	1	1	1	1
⊙	5	2C907120	ACTUATOR EMPTY	1	1	1	1
⊙	6	2C907130	GEAR Z15 REGIST	1	1	1	1
	7	2C907160	RIGHT GUIDE REGIST	1	1	1	1
⊙	8	2C907170	ACTUATOR REGIST	1	1	1	1
	9	2C907180	RIGHT ROLL REGIST	1	1	1	1
	10	2C907210	SHAFT PAPER FEED	1	1	1	1
	11	2C907230	SHAFT PICK UP B	1	1	1	1
	12	2C907240	PLATE PICK UP B	1	1	1	1
	13	2C907250	HOLDER RETARD	1	1	1	1
⊙	14	2C907260	SLIDER RAIL	2	2	2	2
	15	2C907270	LEVER PICK UP	1	1	1	1
⊙	16	2C907280	TORQUE LIMITER 340	1	1	1	1
	17	2C907300	SHAFT RETARD	1	1	1	1
⊙	18	2C907290	SPRING REGIST B	1	1	1	1
	19	2C907320	SPRING RETARD	1	1	1	1
	20	2C907340	SPRING PICK UP	2	2	2	2
	21	2C907350	SPRING LEVER	1	1	1	1
	22	2C907400	HOLDER PULLEY A	1	1	1	1
	23	2C907410	PULLEY GUIDE A	1	1	1	1
	24	2C907420	HOLDER FEED SHAFT	1	1	1	1
⊙	25	2C907430	BUSH PAPER FEED C	2	2	2	2
	26	2C907440	RIGHT MOUNT REGIST	1	1	1	1
⊙	27	2C993210	PARTS,REGIST CLEANER,ASSY	1	1	1	1
	28	2C917190	FILM RIGHT TRANS GUIDE	1	1	1	1
	29	2C907470	GROUND PLATE REG R	1	1	1	1
	30	2C907480	HOLDER SENSOR	1	1	1	1
	31	2C907510	GROUND PLATE CASS	1	1	1	1
	32	2C907530	FILM REGIST R	2	2	2	2
	33	2C907540	GROUND PLATE REG F	1	1	1	1
	34	2C917140	GUIDE TRANS RIGHT	1	1	1	1
⊙	35	2C927210	SENSOR 248NL1	1	1	1	1
	36	2C927520	WIRE CASSETTE PCB	1	1	1	1
	37	2C927670	WIRE CASSETTE SW	1	1	1	1
	38	2C927750	WIRE CASSETTE PE	1	1	1	1
⊙	39	2AR07220	PULLEY,PAPER FEED	1	1	1	1
⊙	40	2AR07230	PULLEY,SEPARATION	1	1	1	1

- Parts with "*" are component parts or sub-assemblies of the assembly appearing immediately above them.
- Parts with "⊙" indicates the spare parts.

SP	Ref. No	Part.No.	Description	Quality			
				110V	120V	230V	240V
⊙	41	2AR07240	PULLEY,LEADING FEED	1	1	1	1
⊙	42	2BC06510	BUSHING 8	2	2	2	2
⊙	43	2BC06910	STOPPER 6	1	1	1	1
⊙	44	2BC06980	STOPPER 5	3	3	3	3
⊙	45	SP000360	PUSH SWITCH 03 SN	1	1	1	1
⊙	46	29807100	GEAR 16,BYPASS	2	2	2	2
⊙	47	3CY07080	BUSHING 6	2	2	2	2
	48	2C907610	SHEET TONER TANK	1	1	1	1
	49	2C907580	FILM BASE RIB	2	2	2	2
	50	2C907640	STOPPER PLATE SIZE	1	1	1	1

- Parts with "*" are component parts or sub-assembly with "*" appearing immediately above them.

FIG. 6 BYPASS SECTION

2C9-2/2FX

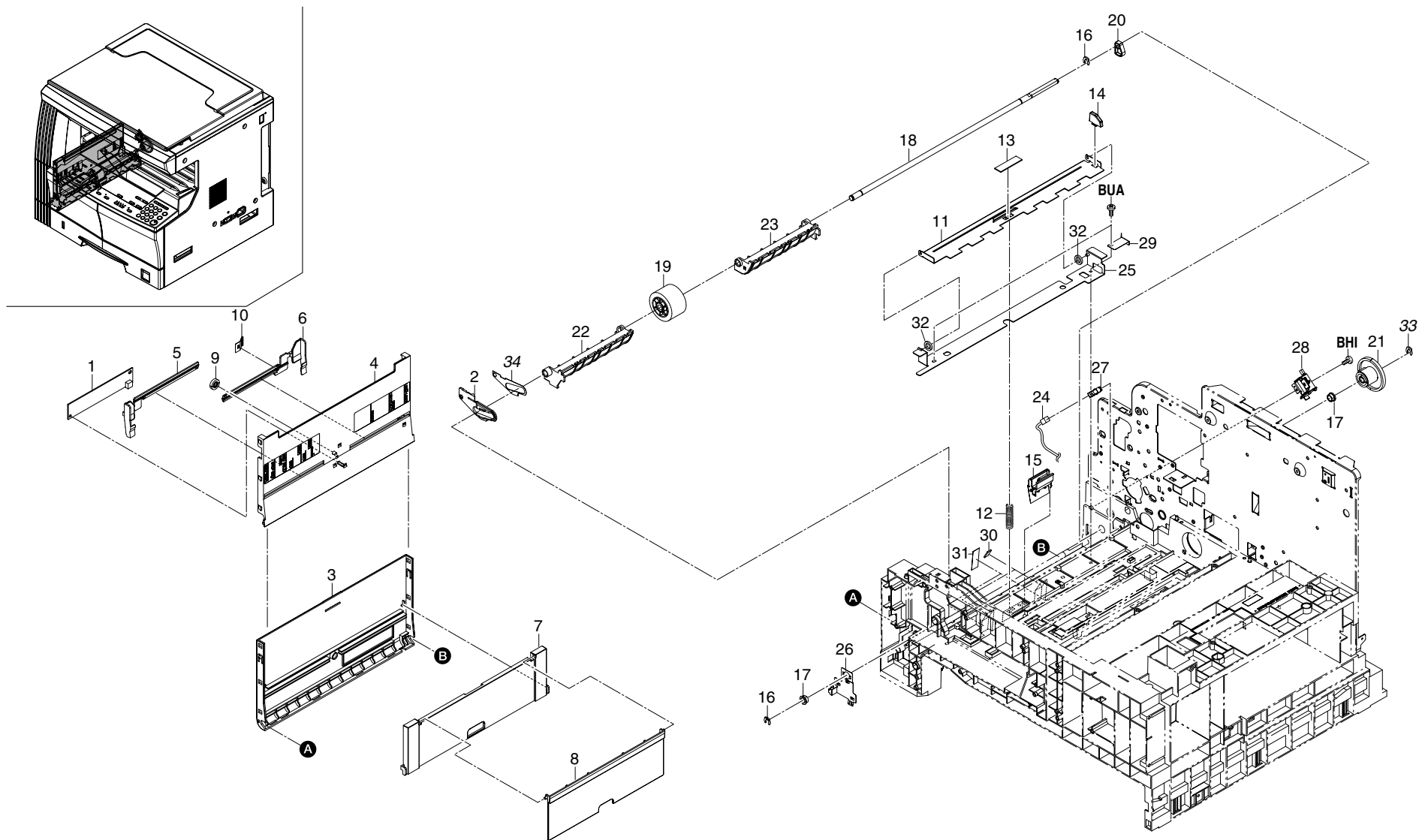

FIG. 6 BYPASS SECTION

2C9-2/2FX

SP	Ref. No	Part.No.	Description	Quality			
				110V	120V	230V	240V
⊙	1	2C901050	PCB MPF SIZE ASSY	1	1	1	1
	2	2C904360	STRAP LEFT COVER C	1	1	1	1
⊙	3	2C906010	COVER BYPASS	1	1	1	1
⊙	4	2C906020	TABLE BYPASS	1	1	1	1
⊙	5	2C906030	FRONT CURSOR BYPASS	1	1	1	1
⊙	6	2C906040	REAR CURSOR BYPASS	1	1	1	1
⊙	7	2C906050	BYPASS SUB TABLE A	1	1	1	1
⊙	8	2C906060	BYPASS SUB TABLE B	1	1	1	1
⊙	9	2C906080	GEAR 18 BYPASS	1	1	1	1
	10	2C906090	TERMINAL PAPER SIZE	1	1	1	1
	11	2C906100	LIFT PLATE BYPASS	1	1	1	1
	12	2C906110	SPRING BYPASS LIFT	1	1	1	1
⊙	13	2C906120	SHEET BYPASS LIFT	1	1	1	1
⊙	14	2C906130	STOPPER BYPASS	1	1	1	1
⊙	15	2C993140	PARTS,BYPASS PAD,SP	1	1	1	1
⊙	16	2BC06910	STOPPER 6	2	2	2	2
⊙	17	2BC06510	BUSHING 8	2	2	2	2
	18	2C906170	SHAFT BYPASS	1	1	1	1
⊙	19	2C993130	PARTS,BYPASS PULLEY,SP	1	1	1	1
⊙	20	2C906190	CAM BYPASS	1	1	1	1
⊙	21	2C906200	CLUTCH BYPASS FEED	1	1	1	1
	22	2C906210	BYPASS PAPER GUIDE F	1	1	1	1
	23	2C906220	BYPASS PAPER GUIDE R	1	1	1	1
	24	2C927620	WIRE MPF	1	1	1	1
	25	2C906240	MOUNT LIFT PLATE	1	1	1	1
	26	2C906250	GROUND PLATE BYPASS	1	1	1	1
⊙	27	2C927210	SENSOR 248NL1	1	1	1	1
⊙	28	2C927050	SOLENOID BYPASS	1	1	1	1
	29	2C906280	GROUND PLATE LIFT	1	1	1	1
	30	2C906290	SHEET BYPASS GUIDE	2	2	2	2
⊙	31	2C906300	SEAL BYPASS GUIDE	2	2	2	2
	32	2C906310	SEAL BYPASS LIFT	2	2	2	2
⊙	33	2BC06980	STOPPER 5	1	1	1	1
	34	2C904490	PLATE FRONT STRAP	1	1	1	1

- Parts with "*" are component parts or sub-assemblies of the assembly appearing immediately above them.
- Parts with "⊙" indicates the spare parts.

- Parts with "••" are component parts or sub-assembly with "•" appearing immediately above them.

FIG. 7 EXIT SECTION

2C9-2/2FX

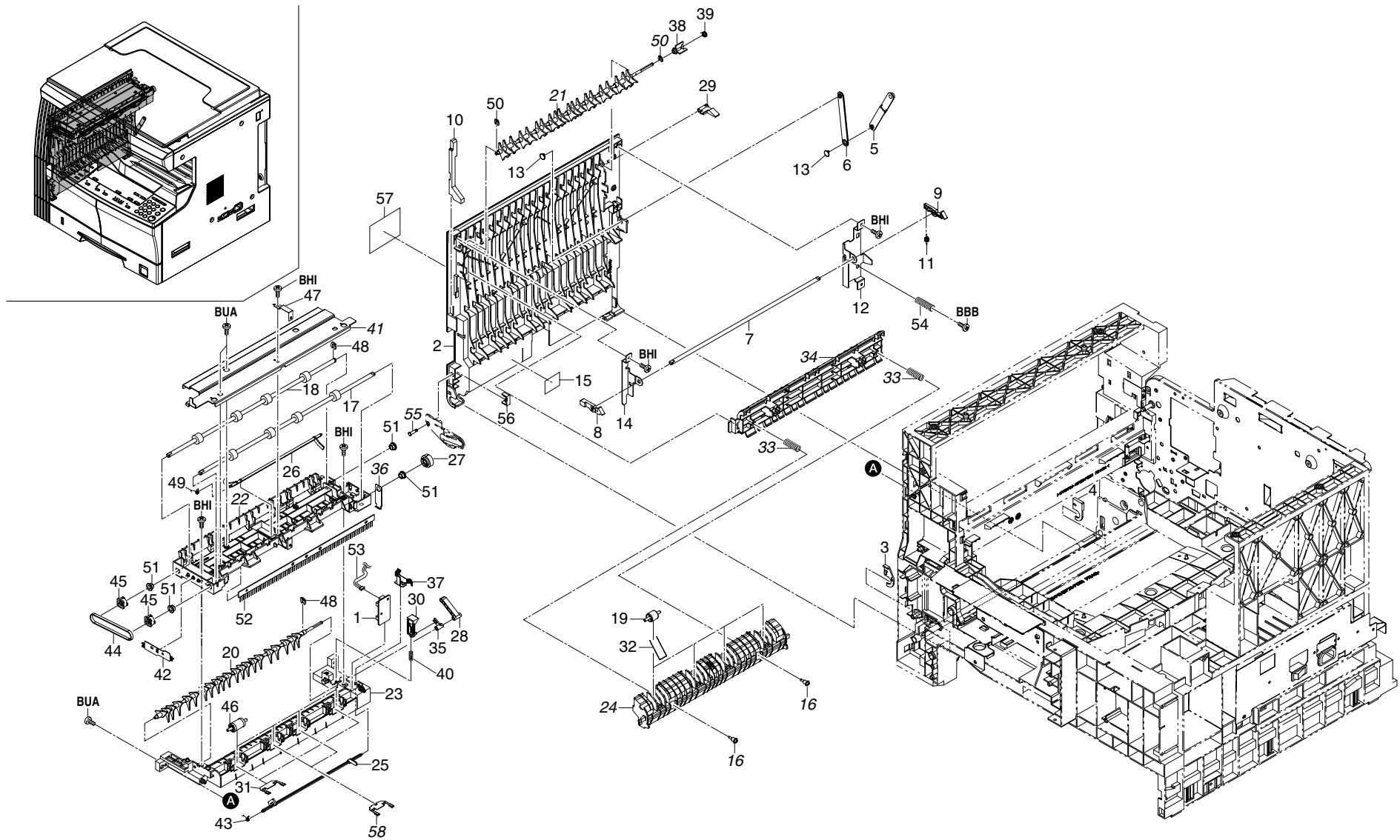

FIG. 7 EXIT SECTION

2C9-2/2FX

SP	Ref. No	Part.No.	Description	Quality			
				110V	120V	230V	240V
⊙	1	2C901060	PCB EJECT SW ASSY	1	1	1	1
⊙	2	2C904050	LEFT COVER	1	1	1	1
	3	2C904210	STOPPER LEFT COVER F	1	1	1	1
	4	2C904220	STOPPER LEFT COVER R	1	1	1	1
	5	2C904230	STRAP LEFT COVER A	1	1	1	1
	6	2C904240	STRAP LEFT COVER B	1	1	1	1
	7	2C904250	SHAFT HOOK	1	1	1	1
	8	2C904260	HOOK LEFT COVER F	1	1	1	1
	9	2C904270	HOOK LEFT COVER R	1	1	1	1
	10	2C904280	JUNCTION PLATE HOOK	1	1	1	1
	11	2C904350	SPRING LEFT HOOK	1	1	1	1
	12	2C904390	PLATE LEFT SW	1	1	1	1
	13	2C904420	PIN STRAP	2	2	2	2
	14	2C904430	PLATE LEFT HOOK	1	1	1	1
⊙	15	2C905090	LABEL HIGH TEMP	1	1	1	1
	16	2C921400	SHOULDER SCREW EXIT	2	2	2	2
⊙	17	2C921010	ROLLER EXIT INNER	1	1	1	1
⊙	18	2C921020	ROLLER FEED SHIFT	1	1	1	1
⊙	19	2C921040	PULLEY FEED SHIFT	4	4	4	4
	20	2C921050	GUIDE SHIFT	1	1	1	1
	21	2C921061	GUIDE SEPARATE	1	1	1	1
	22	2C921071	HOUSING EXIT UPPER	1	1	1	1
	23	2C921080	HOUSING EXIT LOWER	1	1	1	1
	24	2C921091	GUIDE EXIT LOWER	1	1	1	1
⊙	25	2C921100	ACTUATOR EXIT INNER	1	1	1	1
⊙	26	2C921110	ACTUATOR EXIT LEFT	1	1	1	1
⊙	27	2C921120	GEAR 23 EXIT	1	1	1	1
	28	2C921150	ARM SHIFT	1	1	1	1
⊙	29	2C921160	ARM SEPARATE	1	1	1	1
	30	2C921180	ARM LINK	1	1	1	1
	31	2C921190	SPRING PULLEY INNER	2	2	2	2
	32	2C921200	SPRING PULLEY FEED SHIFT	4	4	4	4
	33	2C921221	SPRING GUIDE DU	2	2	2	2
	34	2C921231	GUIDE DU	1	1	1	1
	35	2C921240	ARM SHIFT B	1	1	1	1
	36	2C921390	PLATE EXIT HOLDER	1	1	1	1
	37	2C921260	PLATE EARTH EXIT 2	1	1	1	1
	38	2C921270	ARM SEPARATE B	1	1	1	1
	39	2C921280	SPRING SEPARATE	1	1	1	1
	40	2C921290	SPRING LINK	1	1	1	1

SP	Ref. No	Part.No.	Description	Quality			
				110V	120V	230V	240V
	41	2C921301	BRACKET EXIT	1	1	1	1
	42	2C921310	PLATE EARTH EXIT B	1	1	1	1
	43	2C921330	SPRING ACTUATOR INNER	1	1	1	1
⊙	44	2C921340	BELT EXIT	1	1	1	1
⊙	45	2C921350	PULLEY EXIT	2	2	2	2
⊙	46	2C921360	PULLEY EJECT	4	4	4	4
	47	2C921370	STOPPER SE	1	1	1	1
⊙	48	2BC06980	STOPPER 5	2	2	2	2
	49	2BL21260	SPRING ACTUATOR L	1	1	1	1
⊙	50	2BT11070	STOPPER 3	2	2	2	2
⊙	51	3CY07080	BUSHING 6	4	4	4	4
⊙	52	34821210	STATIC ELIMINATOR B,EJECT	1	1	1	1
	53	2C927530	WIRE EJECT	1	1	1	1
	54	2C904440	SPRING LEFT COVER	1	1	1	1
⊙	55	2C904500	PIN LEFT COVER	1	1	1	1
⊙	56	2C904460	COVER FRONT STRAP	1	1	1	1
⊙	57	2C905170	LABEL BYPASS TABLE	1	1	1	1
	58	2C921380	SPRING PULLEY EJECT	1	1	1	1

• Parts with "*" are component parts or sub-assemblies of the assembly appearing immediately above them.
 • Parts with "⊙" indicates the spare parts.

• Parts with "*" are component parts or sub-assembly with "*" appearing immediately above them.

FIG. 8 SCANNER SECTION

2C9-2/2FX

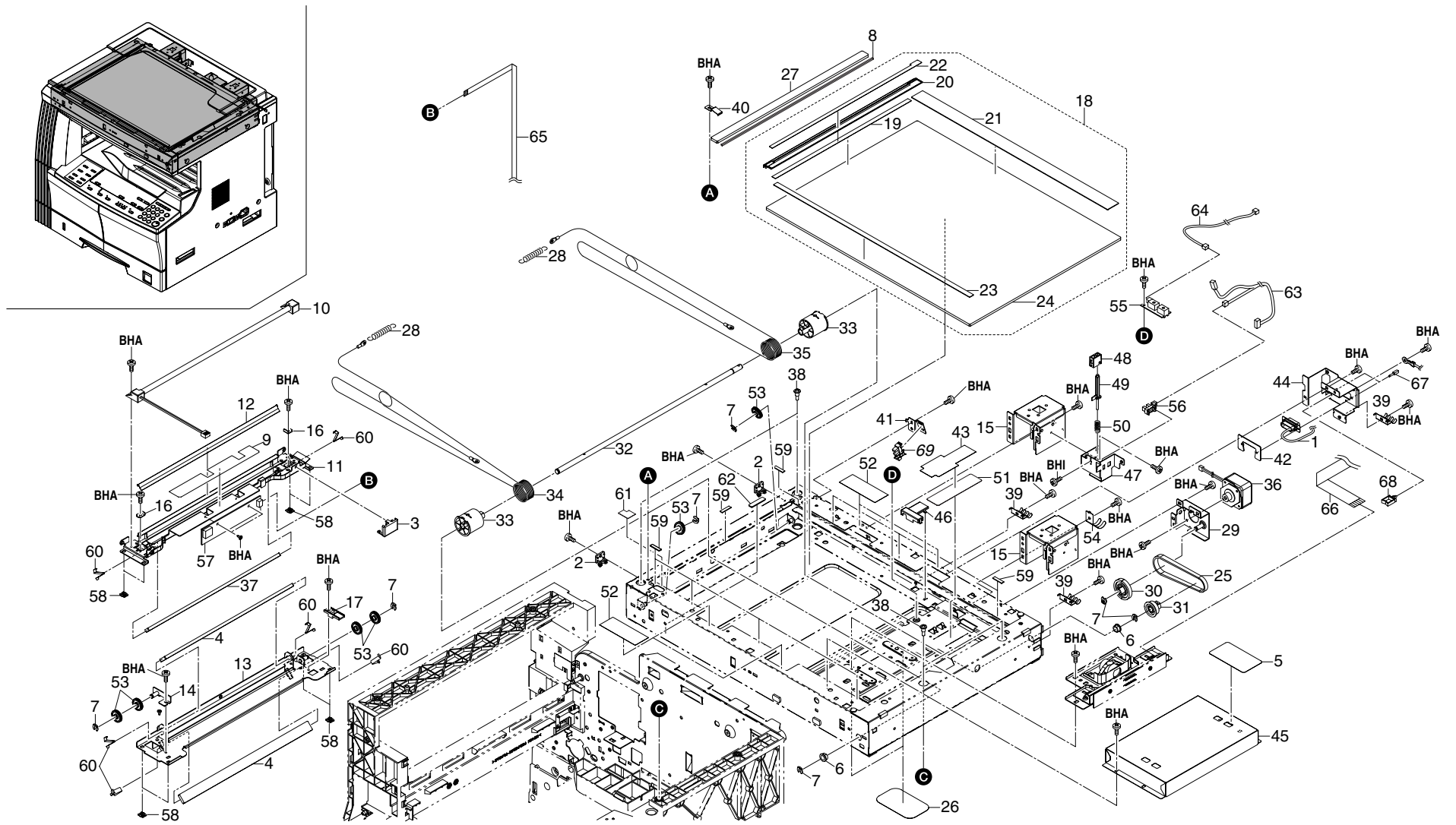

FIG. 8 SCANNER SECTION

2C9-2/2FX

SP	Ref. No	Part.No.	Description	Quality			
				110V	120V	230V	240V
	1	2C927540	WIRE DP	1	1	1	1
	2	18512340	GUIDE,SCANNER WIRE	2	2	2	2
	3	2AV12080	GUIDE FFC1	1	1	1	1
⊙	4	2AV12160	MIRROR B	2	2	2	2
⊙	5	2C905160	LABEL GLASS CAUTION	1	1	1	1
⊙	6	2BC06510	BUSHING 8	2	2	2	2
⊙	7	2BC06980	STOPPER 5	7	7	7	7
⊙	8	2C912700	SPONGE ORIGINAL SIZE	1	1	1	1
	9	2C912180	FILM FRAME A	1	1	1	1
⊙	10	2C912090	LAMP SCANNER YG	1	1	1	1
	11	2C912100	MIRROR FRAME A	1	1	1	1
	12	2C912110	REFLECTOR SCANNER	1	1	1	1
	13	2C912120	MIRROR FRAME B	1	1	1	1
	14	2C912130	ADJUSTING PLATE B	1	1	1	1
	15	2C912140	MOUNT BASE DF HINGE LEFT	2	2	2	2
	16	2C912150	RETAINER WIRE	2	2	2	2
	17	2C912160	GUIDE FFC B	1	1	1	1
⊙	18	2C993170	PARTS,CONTACT GLASS,M(SP)	1		1	1
⊙	18	2C993180	PARTS,CONTACT GLASS,I(SP)		1		
	19	•2C912190	STANDARD PLATE SHADING	1	1	1	1
	20	•2C912200	LEFT SIZE INDICATOR	1	1	1	1
	21	•2C912210	REAR SIZE INDICATOR(M)	1		1	1
	21	•2C912460	REAR SIZE INDICATOR(I)		1		
	22	•2C912440	LABEL SIZE (METRIC)	1		1	1
	22	•2C912450	LABEL SIZE (INCH)		1		
	23	•2C912600	FRONT SIZE INDICATOR	1	1	1	1
	24	•2C912250	CONTACT GLASS	1	1	1	1
⊙	25	2C912260	BELT SCANNER	1	1	1	1
	26	2C912270	LOWER SEAL SCANNER	2	2	2	2
⊙	27	2C912280	CONTACT GLASS ADF	1	1	1	1
	28	2C912290	SPRING SCANNER TENSION	2	2	2	2
	29	2C912300	MOTOR PLATE SCANNER	1	1	1	1
⊙	30	2C912310	GEAR Z18/39	1	1	1	1
⊙	31	2C912320	GEAR Z36	1	1	1	1
	32	2C912330	SHAFT MOTOR DRIVE	1	1	1	1
⊙	33	2C912340	DRUM PULLEY	2	2	2	2
	34	2C912350	FRONT WIRE SCANNER	1	1	1	1
	35	2C912360	REAR WIRE SCANNER	1	1	1	1
⊙	36	2C912380	MOTOR SCANNER	1	1	1	1
⊙	37	2C912390	MIRROR A	1	1	1	1

- Parts with "*" are component parts or sub-assemblies of the assembly appearing immediately above them.
- Parts with "⊙" indicates the spare parts.

SP	Ref. No	Part.No.	Description	Quality			
				110V	120V	230V	240V
	38	2C912400	PIN SCANNER RETAINING	4	4	4	4
	39	2C912410	GROUND PLATE SCANNER	3	3	3	3
	40	2C912420	HOLDER GLASS DF	1	1	1	1
	41	2C912220	MOUNT PI	1	1	1	1
	42	2C912470	PLATE DSUB	1	1	1	1
	43	2C912480	HOLDER CCD WIRE	1	1	1	1
	44	2C912490	MOUNT DSUB	1	1	1	1
	45	2C912580	COVER ISU	1	1	1	1
	46	2C912230	HOLDER FFC A	1	1	1	1
	47	2C912610	MOUNT RELEASE SWITCH	1	1	1	1
	48	2C912620	GUIDE RELEASE SWITCH	1	1	1	1
	49	2C912640	SHAFT RELEASE SWITCH	1	1	1	1
	50	2C912650	SPRING RELEASE SWITCH	1	1	1	1
	51	2C912660	GUIDE CCD WIRE	1	1	1	1
	52	2C912670	SHIELD SCANNER FRAME	4	4	4	4
⊙	53	2C912680	PULLEY SCANNER	6	6	6	6
	54	2C912690	GROUND PLATE SCANNER B	1	1	1	1
⊙	55	2C927090	SENSOR ORIGINAL	1	1	1	1
⊙	56	2C927210	SENSOR 248NL1	1	1	1	1
⊙	57	2C928040	PCB LAMP INVERTER	1	1	1	1
	58	2DC12230	SLIDER SCANNER	8	8	8	8
⊙	59	29812291	CUSHION,CONTACT GLASS	9	9	9	9
	60	35912210	SPRING,MIRROR HOLDER	6	6	6	6
	61	2C912710	SHIELD SCANNER FRAME B	1	1	1	1
	62	2C912720	SHIELD BASE	1	1	1	1
	63	2C927550	WIRE SCANNER PI	1	1	1	1
	64	2C927560	WIRE ORIGINAL SIZE	1	1	1	1
⊙	65	2C927580	FFC INVERTER	1	1	1	1
⊙	66	2C927630	FFC CCD	1	1	1	1
	67	M0208000	SPACER,SFS-4S-B1WM(JST)	2	2	2	2
	68	M2109000	WIRE SADDLE,WS-1NS	1	1	1	1
⊙	69	2DC27180	SWITCH PI	1	1	1	1

- Parts with "*" are component parts or sub-assembly with "*" appearing immediately above them.

FIG. 9 IMAGING UNIT

2C9/2FX

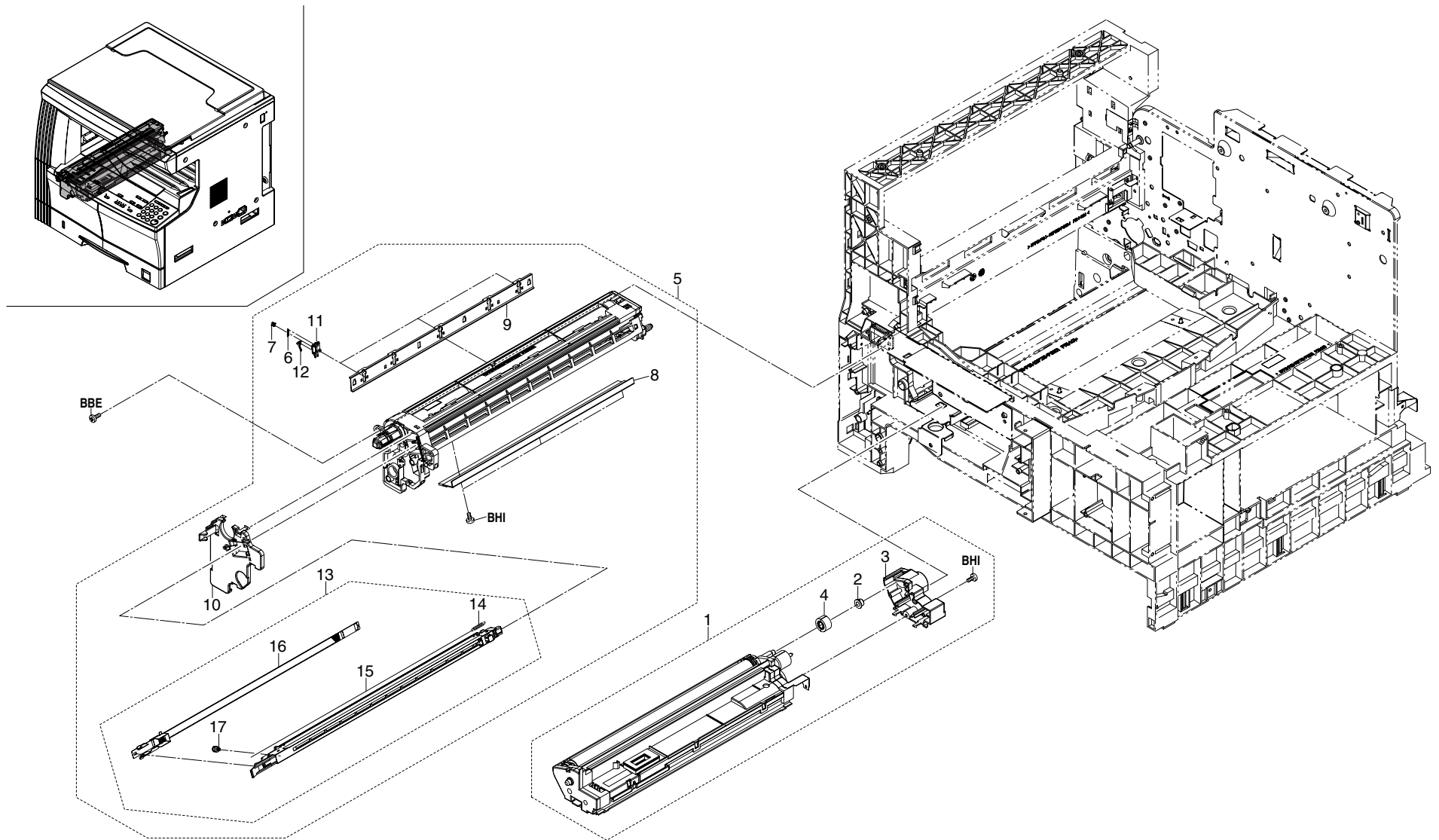

FIG. 9 IMAGING UNIT

2C9/2FX

SP	Ref. No	Part.No.	Description	Quality			
				110V	120V	230V	240V
⊙	1	2C993030	PARTS,DV-410,SP	1	1	1	1
	2	•2BZ22140	BUSH GEAR Z26H	1	1	1	1
	3	•2C914080	REAR COVER DLP	1	1	1	1
	4	•2C914280	GEAR Z20H B	1	1	1	1
⊙	5	2C982010	SET MK-410	1	1	1	1
	6	•2AR18280	SPRING,CLAW SEPARATION	3	3	3	3
	7	•2A118370	PULLEY,DRUM SEPARATION	3	3	3	3
	8	•2C918010	BLADE CLEANING	1	1	1	1
	9	•2C918040	LOWER SEAL CLEANING	1	1	1	1
	10	•2C918050	FRONT COVER CLEANING	1	1	1	1
	11	•2C918340	HOLDER CLAW	3	3	3	3
	12	•2C918370	CLAW SEPARATION	3	3	3	3
⊙	13	•2C993020	PARTS,MC-410,SP	1	1	1	1
	14	••2BZ02300	SPRING WIRE	1	1	1	1
	15	••2CK10060	CORONA WIRE MCH	1	1	1	1
	16	••2C910040	GRID	1	1	1	1
	17	••33910230	PIN CHARGER	1	1	1	1

- Parts with "•" are component parts or sub-assemblies of the assembly appearing immediately above them.
- Parts with "⊙" indicates the spare parts.

- Parts with "••" are component parts or sub-assembly with "•" appearing immediately above them.

FIG. 10 FUSER UNIT

2C9/2FX

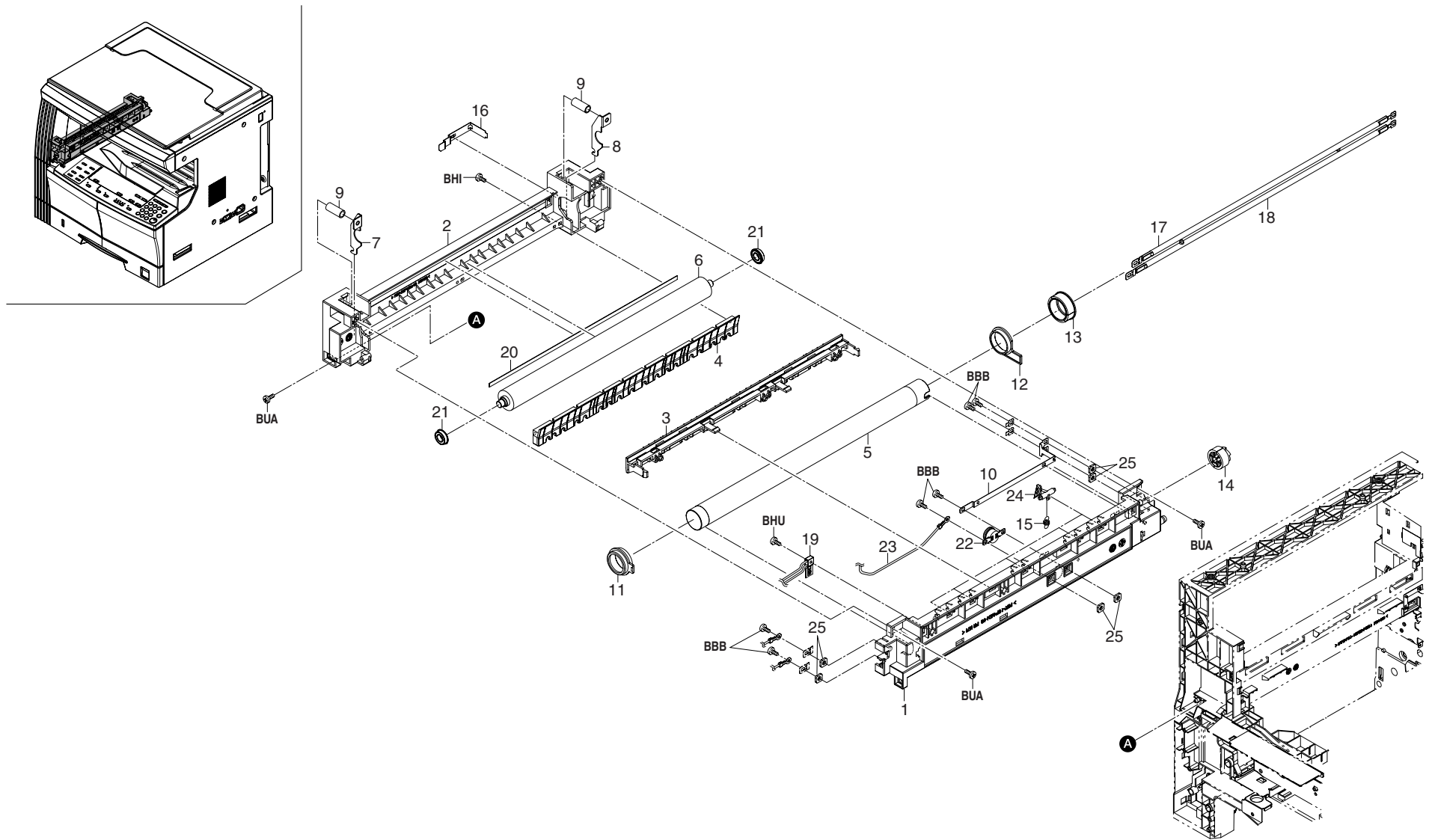

FIG. 10 FUSER UNIT

2C9/2FX

SP	Ref. No	Part.No.	Description	Quality			
				110V	120V	230V	240V
⊙		2C993050	PARTS,FK-410(A),SP	1	1		
⊙		2C993060	PARTS,FK-410(E),SP			1	1
	1	•2C920010	RIGHT FRAME FUSER	1	1	1	1
	2	•2C920020	LEFT FRAME FUSER	1	1	1	1
	3	•2C920030	REAR GUIDE FUSER	1	1	1	1
	4	•2C920040	FRONT GUIDE FUSER	1	1	1	1
⊙	5	•2C920050	ROLLER HEAT	1	1	1	1
⊙	6	•2C920060	ROLLER PRESS	1	1	1	1
	7	•2C920110	FRONT PRESSING PLATE	1	1	1	1
	8	•2C920120	REAR PRESSING PLATE	1	1	1	1
	9	•2C920130	SPRING PRESSURE	2	2	2	2
	10	•2C920140	PLATE HEATER FUSER	1	1	1	1
⊙	11	•2C920150	FRONT BUSH HEAT ROLLER	1	1	1	1
⊙	12	•2C920160	REAR BUSH HEAT ROLLER	1	1	1	1
⊙	13	•2C920170	GEAR Z38 HEAT ROLLER	1	1	1	1
⊙	14	•2C920180	GEAR FUSER Z28	1	1	1	1
⊙	15	•2C920190	SPRING SEPARATOR	5	5	5	5
	16	•2C920200	GROUND PLATE PRESS	1	1	1	1
⊙	17	•2C920230	HEATER M120 FUSER	1	1		
⊙	17	•2C920250	HEATER M230 FUSER			1	1
⊙	18	•2C920240	HEATER S120 FUSER	1	1		
⊙	18	•2C920260	HEATER S230 FUSER			1	1
⊙	19	•2C920310	THERMISTOR FUSER	1	1	1	1
	20	•2C920320	SEAL DISCHAGER	1	1	1	1
⊙	21	•2C920330	BEARING PRESSURE	2	2	2	2
⊙	22	•2C920340	THERMOCUT 180 FUSER	1	1	1	1
	23	•2C927690	WIRE FUSER UNIT	1	1	1	1
⊙	24	•2BR20240	SEPARATOR ASSY	5	5	5	5
	25	•2BY20050	NUT FUSER A	6	6	6	6

- Parts with "•" are component parts or sub-assemblies of the assembly appearing immediately above them.
- Parts with "⊙" indicates the spare parts.

- Parts with "••" are component parts or sub-assembly with "•" appearing immediately above them.

FIG. 11 DRIVING & COOLING SECTION

2C9/2FX

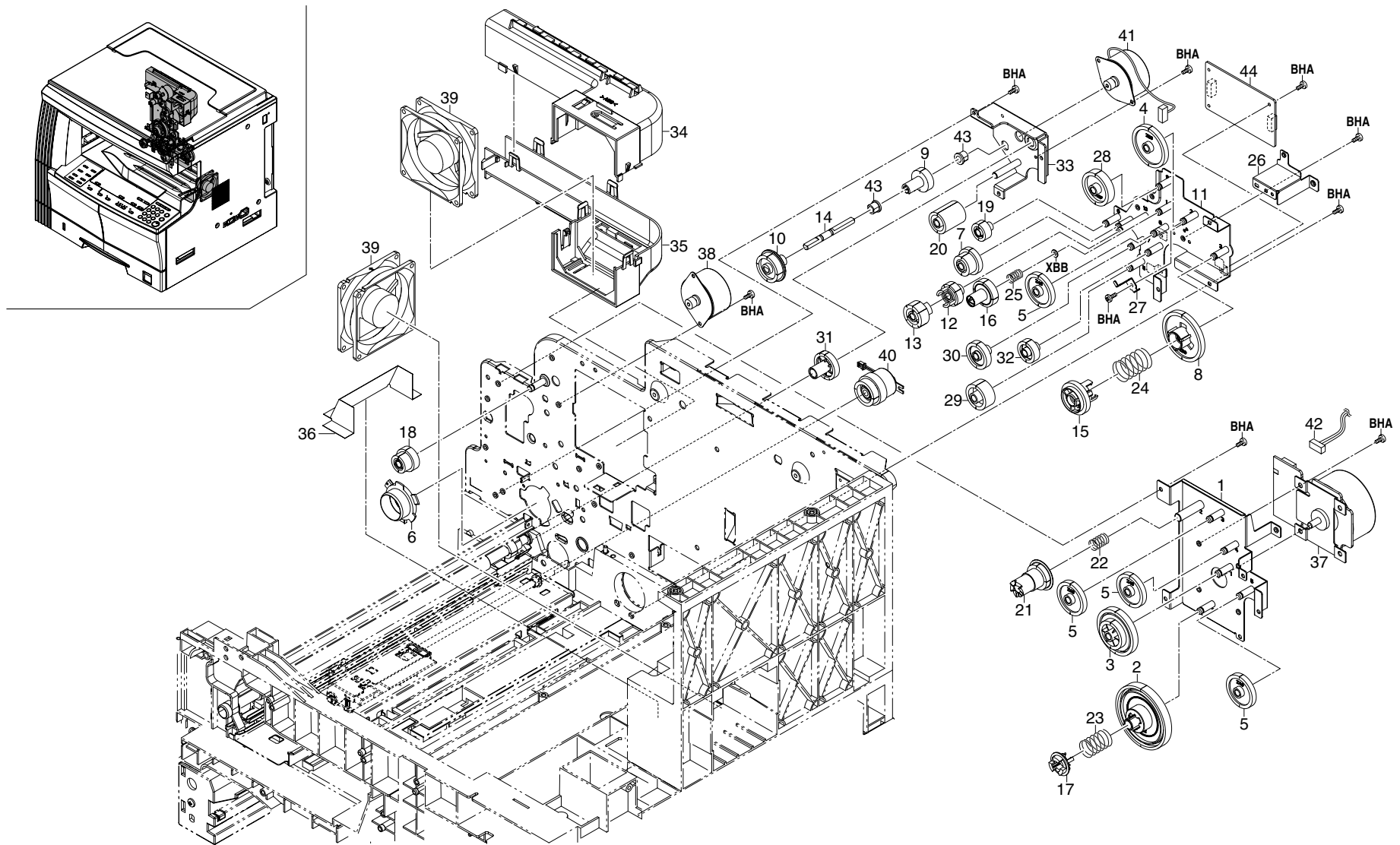

FIG. 11 DRIVING & COOLING SECTION

2C9/2FX

SP	Ref. No	Part.No.	Description	Quality			
				110V	120V	230V	240V
	1	2C922010	MOUNT DRIVE UNIT	1	1	1	1
⊙	2	2C922020	GEAR 122	1	1	1	1
⊙	3	2C922030	GEAR 88/34	1	1	1	1
⊙	4	2C922040	GEAR 50	1	1	1	1
⊙	5	2C922050	GEAR 40	4	4	4	4
⊙	6	2C922060	POSITIONING BUSH DRUM	1	1	1	1
⊙	7	2C922070	GEAR 30/23	1	1	1	1
⊙	8	2C922080	GEAR 60	1	1	1	1
⊙	9	2C922100	GEAR 25 DPX	1	1	1	1
⊙	10	2C922110	GEAR 32 DPX	1	1	1	1
	11	2C922130	MOUNT CONT DRIVE	1	1	1	1
⊙	12	2C922140	GEAR 25 DEV	1	1	1	1
⊙	13	2C922150	GEAR 26 DEV	1	1	1	1
⊙	14	2C922160	SHAFT DPX DRIVE	1	1	1	1
⊙	15	2C922170	COUPLING CONT P	1	1	1	1
⊙	16	2C922180	COUPLING CONT S	1	1	1	1
⊙	17	2C922190	COUPLING DRUM	1	1	1	1
⊙	18	2C922200	GEAR 43/20	1	1	1	1
⊙	19	2C922210	GEAR 20	1	1	1	1
⊙	20	2C922220	GEAR 25	1	1	1	1
⊙	21	2C922230	GEAR 29 FIX JOINT	1	1	1	1
	22	2C922240	SPRING FIX JOINT	1	1	1	1
	23	2C922250	SPRING DRUM COUPLING	1	1	1	1
	24	2C922260	SPRING CONT P	1	1	1	1
	25	2C922270	SPRING CONT S	1	1	1	1
	26	2C922280	MOUNT HV PCB	1	1	1	1
	27	2C922290	HOLDER GEAR	1	1	1	1
⊙	28	2C922300	GEAR 40 FIXJOINT	1	1	1	1
⊙	29	2C922330	GEAR 30 PF	1	1	1	1
⊙	30	2C922340	GEAR 31	1	1	1	1
⊙	31	2C922350	GEAR 51 REG	1	1	1	1
⊙	32	2C922360	GEAR 25 PF	1	1	1	1
	33	2C922370	MOUNT REG MOTOR	1	1	1	1
	34	2C923010	UPPER DUCT	1	1	1	1
	35	2C923020	LOWER DUCT	1	1	1	1
	36	2C923030	FILM COOLING	1	1	1	1
⊙	37	2C927010	MOTOR MAIN	1	1	1	1
⊙	38	2C927020	MOTOR EJECT	1	1	1	1
⊙	39	2C927070	FAN COOLING 80-25	2	2	2	2
⊙	40	2C927190	CLUTCH FEED	1	1	1	1

- Parts with "*" are component parts or sub-assemblies of the assembly appearing immediately above them.
- Parts with "⊙" indicates the spare parts.

SP	Ref. No	Part.No.	Description	Quality			
				110V	120V	230V	240V
⊙	41	2C927220	MOTOR REGISTRATION	1	1	1	1
	42	2C927760	WIRE MAIN MOTOR	1	1	1	1
⊙	43	3CY07080	BUSHING 6	2	2	2	2
⊙	44	2C901190	PCB REGISTRATION ASSY	1	1	1	1

- Parts with "*" are component parts or sub-assembly with "*" appearing immediately above them.

FIG. 12 ELECTRICAL COMPONENTS

2C9-2/2FX

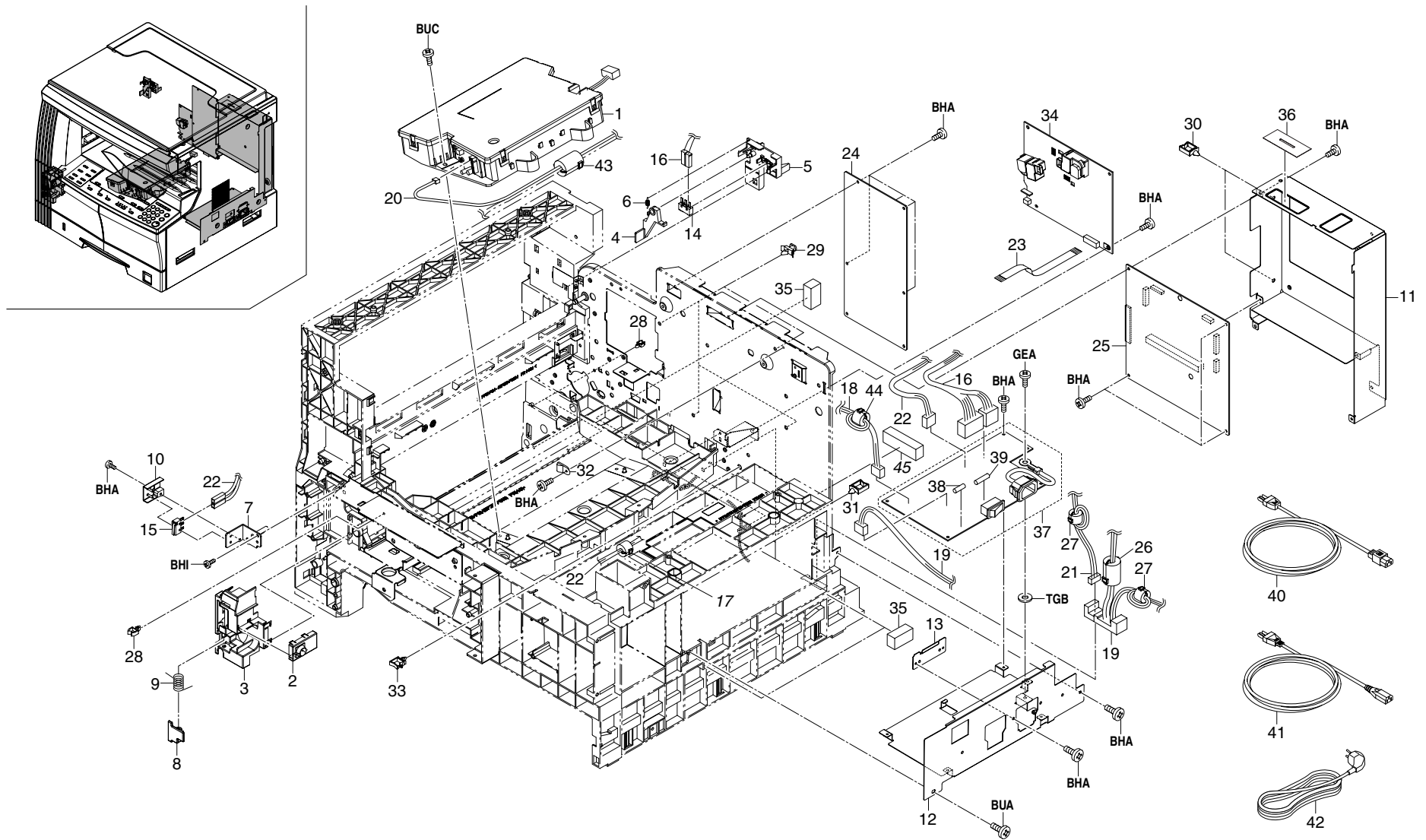

FIG. 12 ELECTRICAL COMPONENTS

2C9-2/2FX

SP	Ref. No	Part.No.	Description	Quality			
				110V	120V	230V	240V
⊙	1	2C993090	PARTS,LSU ASS'Y,SP	1	1	1	1
⊙	2	2C901170	DISPOSAL SENSOR ASSY	1	1	1	1
	3	2C918400	HOLDER SENSOR B	1	1	1	1
	4	2C904300	ARM INTERLOCK SW	1	1	1	1
	5	2C904310	MOUNT INTERLOCK SW	1	1	1	1
	6	2C904340	SPRING LEFT INTERLOCK	1	1	1	1
	7	2C916150	PIN CONVEYING HOOK	1	1	1	1
	8	2C918350	DETECTION PLATE	1	1	1	1
	9	2C918360	SPRING DETECTION	1	1	1	1
	10	2C926070	HOLDER INTERLOCK SW	1	1	1	1
	11	2C926500	SHIELD MAIN	1	1	1	1
	12	2C926510	MOUNT POWER SOURCE	1	1	1	1
	13	2C926520	PLATE INLET	1	1	1	1
⊙	14	2C927170	SWITCH INTERLOCK L	1	1	1	1
⊙	15	2C927180	SWITCH INTERLOCK F	1	1	1	1
	16	2C927510	WIRE ENGINE	1	1	1	1
	17	2A627940	CORE 10-20X10			1	1
	18	2C927600	WIRE FUSER	1	1	1	1
	19	2C927610	WIRE DESK POWER	1	1	1	1
	20	2C927650	WIRE LASER	1	1	1	1
	21	2C927660	WIRE DESK	1	1	1	1
	22	2C927680	WIRE FRONT SW	1	1	1	1
	23	2C927740	FFC HVU	1	1	1	1
⊙	24	2C968182	PCB ENGINE ASSY,SP(KM-1620)	1	1	1	1
⊙	24	2FX68010	PCB ENGINE ASSY,SP(KM-2020)		1	1	1
⊙	25	2C968190	PCB MAIN ASSY,SP	1	1	1	1
⊙	26	2C927230	CORE SFT-72SNB-026K	1	1	1	1
	27	2A627940	CORE 10-20X10	2	2	2	2
	28	M2105740	MINIATURE CLAMP,UAMS-05S-2	4	4	4	4
	29	M2108130	SPACER,KGPS-4S	3	3	3	3
	30	M2109000	WIRE SADDLE,WS-1NS	2	2	2	2
	31	M2109020	WIRE SADDLE,WS-2WS	1	1	1	1
	32	M7005030	CLAMP,EMT-5N(TAKEUCHI)	1	1	1	1
	33	M70A5020	CLAMP,FCC-125EM513(TAKEUCHI)	1	1	1	1
	34	2C928050	PCB HIGH VOLTAGE	1	1	1	1
⊙	35	2BL14480	SEAL WIRE	4	4	4	4
	36	2C926160	SHIELD CCD WIRE	1	1	1	1
	37	2C928080	PCB LVU 100	1	1		
⊙	37	2C928090	PCB LVU 200			1	1
⊙	38	*M5561000	FUSE,CES6-N1(SOC)	1	1		

SP	Ref. No	Part.No.	Description	Quality			
				110V	120V	230V	240V
⊙	38	*M1658030	FUSE,215008(LITTEL-FUSE)			1	1
⊙	39	*M6056000	FUSE,19181-T6.3H(WICKMANN)			1	1
⊙	40	65027600	POWER CORD 110	1			
	41	19527400	POWER CORD(120)		1		
	42	2AN27360	POWER CORD(230)			1	1
	43	2AV27440	CORE 15-26X13	1	1	1	1
	44	2A627930	CORE 11-25X14			1	1
	45	2C927250	GASKET SHIELD 8X10X45			1	1

- Parts with "*" are component parts or sub-assemblies of the assembly appearing immediately above them.
- Parts with "⊙" indicates the spare parts.

- Parts with "*" are component parts or sub-assembly with "*" appearing immediately above them.

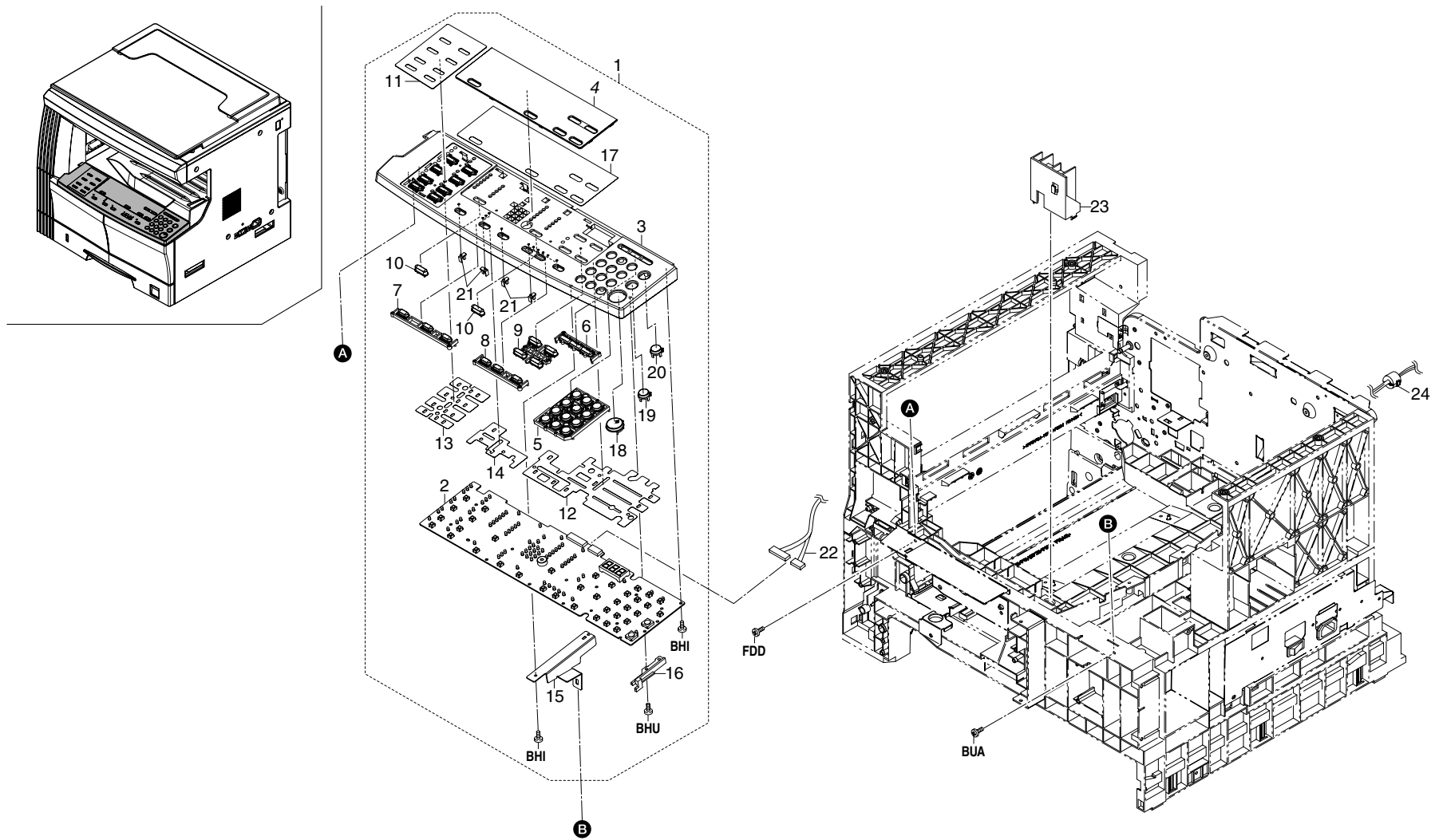

FIG. 13 OPERATION UNIT

2C9-2/2FX

SP	Ref. No	Part.No.	Description	Quality			
				110V	120V	230V	240V
⊙	1	2C993081	PARTS,OPE ASS'Y(I)SP		1		
⊙	1	2C993101	PARTS,OPE ASS'Y(M)SP	1		1	1
⊙	2	•2C901040	PCB OPERATION ASSY	1	1	1	1
⊙	3	•2C925100	COVER OPERATION E		1	1	1
⊙	3	•2C925220	COVER OPERATION(RS)	1			
⊙	4	•2C925330	CENTER OPE COVER	1	1	1	1
⊙	5	•2C925030	KEY OPERATION 10	1	1	1	1
⊙	6	•2C925040	KEY SAVER	1	1	1	1
⊙	7	•2C925050	KEY PROGRAM	1	1	1	1
⊙	8	•2C925060	KEY EXPOSURE	1	1	1	1
⊙	9	•2C925070	KEY ZOOM	1	1	1	1
⊙	10	•2C925080	KEY SIZE	2	2	2	2
⊙	11	•2C925120	LEFT OPE SHEET I		1	1	1
⊙	11	•2C925240	LEFT OPE SHEET(RS)	1			
	12	•2C925150	RIGHT DUST SHIELD	1	1	1	1
	13	•2C925160	LEFT DUST SHIELD	1	1	1	1
	14	•2C925170	CENTER DUST SHIELD	1	1	1	1
	15	•2C925200	MOUNT OPERATION R	1	1	1	1
	16	•2C925210	SPACER OPE PCB	1	1	1	1
	17	•2C925260	CENTER OPE SHEET I		1		
	17	•2C925270	CENTER OPE SHEET M			1	1
	17	•2C925280	CENTER OPE SHEET(RS)	1			
⊙	18	•2DC25050	KEY PRINT	1	1	1	1
⊙	19	•2DC25060	KEY STOP	1	1	1	1
⊙	20	•2DC25070	KEY RESET	1	1	1	1
⊙	21	•2C925320	LENS OPERATION COVER	11	11	11	11
	22	2C927640	WIRE PANEL	1	1	1	1
	23	2C925180	RETAINER OPERATION	1	1	1	1
	24	2A627940	CORE 10-20X10	1	1	1	1

- Parts with "•" are component parts or sub-assemblies of the assembly appearing immediately above them.
- Parts with "⊙" indicates the spare parts.

- Parts with "••" are component parts or sub-assembly with "•" appearing immediately above them.

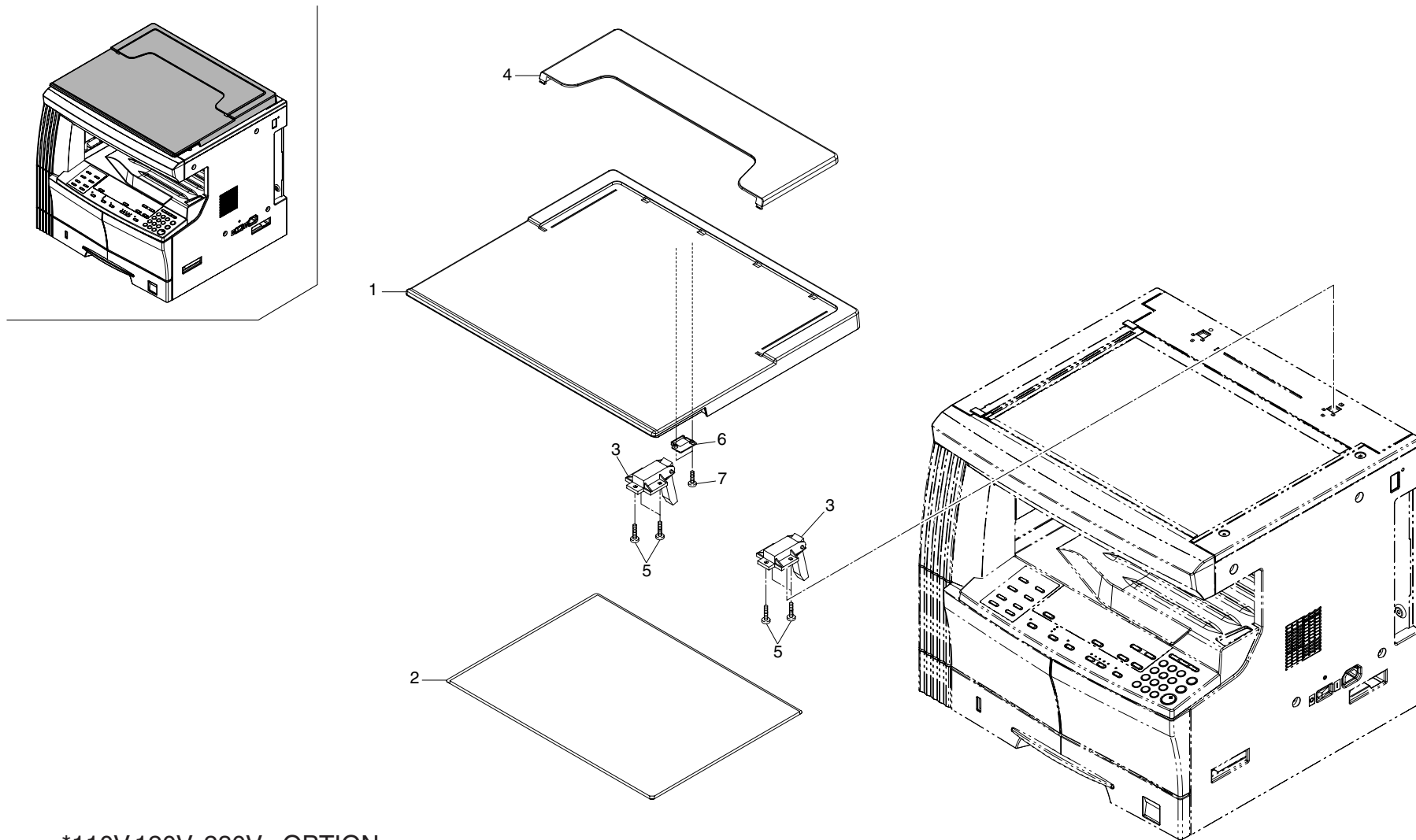

*110V,120V, 230V : OPTION

FIG. 14 ORIGINAL HOLDER

2C9/2FX

SP	Ref. No	Part.No.	Description	Quality			
				110V	120V	230V	240V
		2CX82010	SET,PLATEN COVER TYPE D	1*	1*	1*	1
	1	•2A612800	COVER,PLATEN	1*	1*	1*	1
	2	•2A612810	MAT,ORIGINAL HOLDER	1*	1*	1*	1
	3	•2A612820	HINGE,ORIGINAL HOLDER	2*	2*	2*	2
	4	•60904280	ORIGINAL POCKET	1*	1*	1*	1
	5	•B8014160	BINDING TAP-TITE P SCREW M4X16	6*	6*	6*	6
	6	•2C912630	STOPPER RELEASE SWITCH	1*	1*	1*	1
	7	•B8013120	BINDING TAP-TITE P SCREW M3X12	2*	2*	2*	2

• Parts with "*" indicates the "Option".

- Parts with "*" are component parts or sub-assemblies of the assembly appearing immediately above them.
- Parts with "⊙" indicates the spare parts.

- Parts with "••" are component parts or sub-assembly with "•" appearing immediately above them.

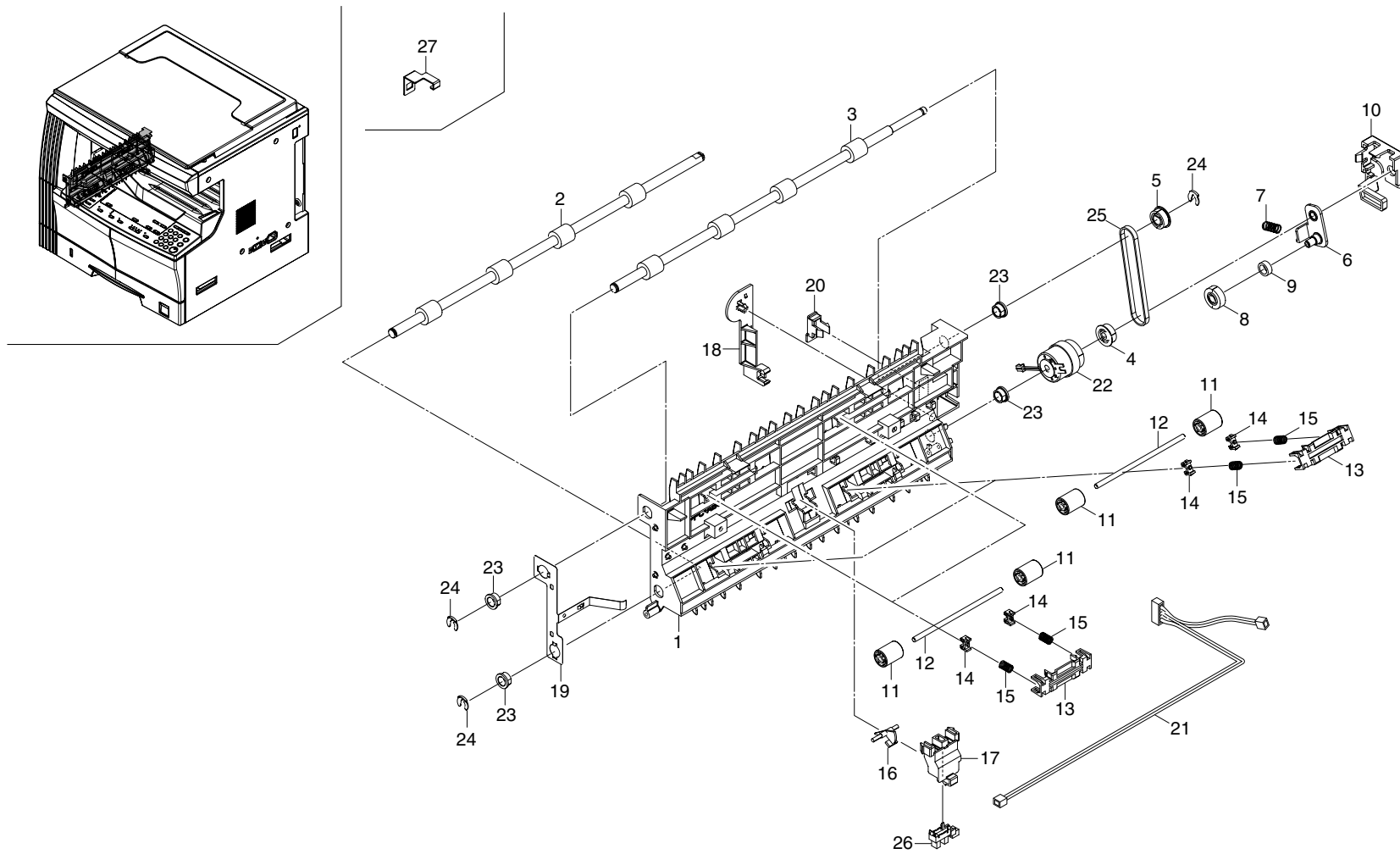

FIG. 15 OPTION I (DU-410)

2C9/2FX

SP	Ref. No	Part.No.	Description	Quality			
				110V	120V	230V	240V
	1	3HY07010	FRAME DUPLEX	1	1	1	1
⊙	2	3HY07020	ROLLER DUPLEX A	1	1	1	1
⊙	3	3HY07030	ROLLER DUPLEX B	1	1	1	1
⊙	4	3HY07040	PULLEY 26-6 DUPLEX	1	1	1	1
⊙	5	3HY07050	PULLEY 26-8 DUPLEX	1	1	1	1
	6	3HY07060	JUNCTION PLATE DUPLEX	1	1	1	1
	7	3HY07070	SPRING JUNCTION DUPLEX	1	1	1	1
⊙	8	3HY07090	GEAR 21 DUPLEX	1	1	1	1
⊙	9	3HY07100	PULLEY IDLE DUPLEX	1	1	1	1
	10	3HY07110	RETAINER DUPLEX	1	1	1	1
⊙	11	3HY07120	PULLEY 15 DUPLEX	8	8	8	8
	12	3HY07130	SHAFT 4 DUPLEX	4	4	4	4
	13	3HY07140	HOLDER DUPLEX SPRING	4	4	4	4
⊙	14	3HY07150	BUSHING DUPLEX ROLLER	8	8	8	8
	15	3HY07160	SPRING DUPLEX PULLEY	8	8	8	8
⊙	16	3HY07170	ACTUATOR DUPLEX	1	1	1	1
	17	3HY07180	RETAINER ACTUATOR	1	1	1	1
	18	3HY07190	PROTECTING PLATE WIRE	1	1	1	1
	19	3HY07200	GROUND PLATE DUPLEX	1	1	1	1
	20	3HY07210	LID DUPLEX	1	1	1	1
	21	3HY27010	WIRE DUPLEX	1	1	1	1
⊙	22	3HY27020	CLUTCH DU	1	1	1	1
⊙	23	2BC06510	BUSHING 8	4	4	4	4
⊙	24	2BC06910	STOPPER 6	3	3	3	3
⊙	25	2C921340	BELT EXIT	1	1	1	1
⊙	26	2C927210	SENSOR 248NL1	1	1	1	1
	27	3HY07220	PLATE LOCK DUPLEX	1	1	1	1

- Parts with "*" are component parts or sub-assemblies of the assembly appearing immediately above them.
- Parts with "⊙" indicates the spare parts.

- Parts with "••" are component parts or sub-assembly with "•" appearing immediately above them.

KEY COUNTER

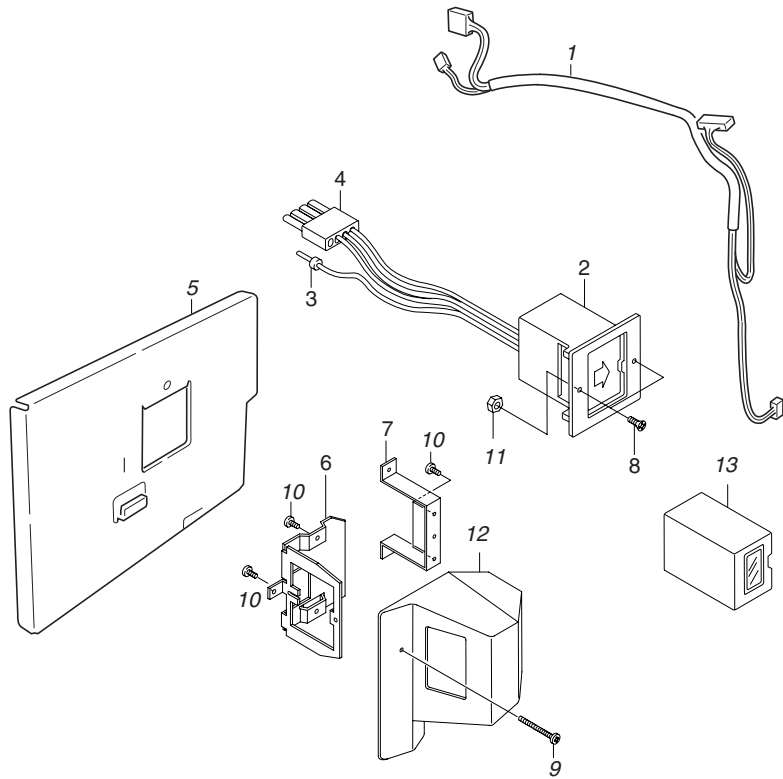

TOOL

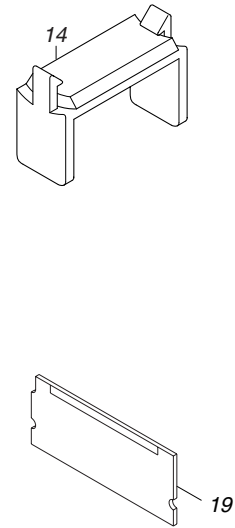

HEATER

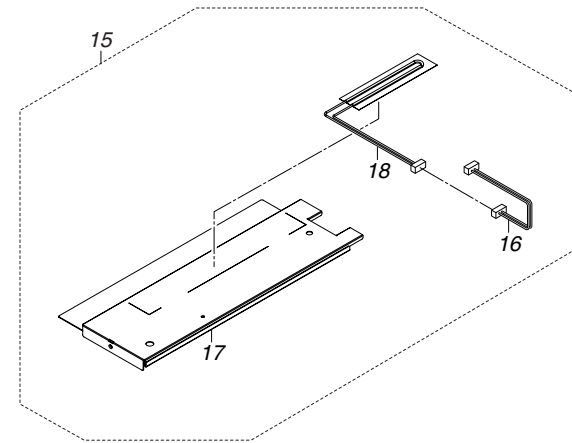

FIG. 16 OPTION II

2C9-2/2FX

SP	Ref. No	Part.No.	Description	Quality			
				110V	120V	230V	240V
⊙	1	2C960110	WIRE KEY COUNTER	1	1	1	1
⊙	2	41529210	SOCKET ASS'Y,KEY COUNTER	1	1	1	1
	3	•J0220040	PLUG EL 4P,ELP-04V	1	1	1	1
	4	•41525016	SOCKET,KEY COUNTER	2	2	2	2
⊙	5	2C960100	MOUNT KEY COUNTER	1	1	1	1
⊙	6	66060030	RETAINER,KEY COUNTER	1	1	1	1
⊙	7	66060040	MOUNT,KEY COUNTER	1	1	1	1
⊙	8	B2303060	COUNTER-SUNK HEAD SCREW BFHM3X6 (B	2	2	2	2
⊙	9	B0004350	ROUND HEAD SCREW M4X35	1	1	1	1
⊙	10	B4304060	TRIPLE SCREW M4X6 (BLACK)	4	4	4	4
⊙	11	C2303000	NUT BNM3 (BLACK)	1	1	1	1
⊙	12	2A360010	COVER,KEY COUNTER	1	1	1	1
⊙	13	82142540	KEY COUNTER	1	1	1	1
⊙	14	35968110	STOPPER WIRE ASS'Y SP	2	2	2	2
⊙	15	2C993190	PARTS,DEH.ASSY120,SP	1	1		
⊙	15	2C993200	PARTS,DEH.ASSY240,SP			1	1
⊙	16	•2C927780	WIRE DEHUMIDIFIER	1	1	1	1
⊙	17	•2C907520	PLATE HEATER J	1	1	1	1
⊙	18	•2AV60100	HEATER,CASSETTE(120)	1	1		
⊙	18	•2AV60110	HEATER,CASSETTE(240)			1	1
⊙	19	2C968132	PCB FLASH DIMM ASSY	1	1	1	1

- Parts with "•" are component parts or sub-assemblies of the assembly appearing immediately above them.
- Parts with "⊙" indicates the spare parts.

- Parts with "••" are component parts or sub-assembly with "•" appearing immediately above them.

INDEX

2C9-2/2FX

SP	Part.No.	Description	Quality				Fig.No.
			110V	120V	230V	240V	
	18512340	GUIDE,SCANNER WIRE	2	2	2	2	8
	19507050	LEVER,CASSETTE BASE RELEASE	1	1	1	1	3
	19527400	POWER CORD(120)		1			12
	2AN27360	POWER CORD(230)			1	1	12
⊙	2AR07220	PULLEY,PAPER FEED	1	1	1	1	5
⊙	2AR07230	PULLEY,SEPARATION	1	1	1	1	5
⊙	2AR07240	PULLEY,LEADING FEED	1	1	1	1	5
	2AR18280	SPRING,CLAW SEPARATION	3	3	3	3	9
	2AV12080	GUIDE FFC1	1	1	1	1	8
⊙	2AV12160	MIRROR B	2	2	2	2	8
	2AV27440	CORE 15-26X13	1	1	1	1	12
	2AV60100	HEATER,CASSETTE(120)	1	1			16
	2AV60110	HEATER,CASSETTE(240)			1	1	16
	2AV73580	LABEL,TONER DISPOSAL TANK HK	1	1	1	1	1
⊙	2A118370	PULLEY,DRUM SEPARATION	5	5	5	5	2,9
	2A360010	COVER,KEY COUNTER	1	1	1	1	16
	2A612800	COVER,PLATEN	1	1	1	1	14
	2A612810	MAT,ORIGINAL HOLDER	1	1	1	1	14
	2A612820	HINGE,ORIGINAL HOLDER	2	2	2	2	14
	2A627930	CORE 11-25X14			1	1	12
	2A627940	CORE 10-20X10	3	3	4	4	12,13
⊙	2A806250	RING STOPPER	1	1	1	1	3
⊙	2BC06510	BUSHING 8	10	10	10	10	5,6,8,15
⊙	2BC06910	STOPPER 6	7	7	7	7	4,5,6,15
⊙	2BC06980	STOPPER 5	14	14	14	14	4,5,6,7,8
⊙	2BL05070	LABEL SEP CLEANING	1	1	1	1	1
	2BL14480	SEAL WIRE	4	4	4	4	12
	2BL16220	BRUSH CLEANER	1	1	1	1	1
⊙	2BL17030	COLLAR TRANS ROLLER	2	2	2	2	4
	2BL21260	SPRING ACTUATOR L	1	1	1	1	7
⊙	2BR20240	SEPARATOR ASSY	5	5	5	5	10
⊙	2BT11070	STOPPER 3	2	2	2	2	7
	2BY20050	NUT FUSER A	6	6	6	6	10
	2BZ02300	SPRING WIRE	1	1	1	1	9
	2BZ22140	BUSH GEAR Z26H	1	1	1	1	9
	2CK10060	CORONA WIRE MCH	1	1	1	1	9
	2CX82010	SET,PLATEN COVER TYPE D	1	1	1	1	14
⊙	2C901040	PCB OPERATION ASSY	1	1	1	1	13
	2C901050	PCB MPF SIZE ASSY	1	1	1	1	6
⊙	2C901060	PCB EJECT SW ASSY	1	1	1	1	7
⊙	2C901100	PCB CASSETTE ASSY	1	1	1	1	5

• Parts with "⊙" indicates the spare parts.

SP	Part.No.	Description	Quality				Fig.No.
			110V	120V	230V	240V	
⊙	2C901170	DISPOSAL SENSOR ASSY	1	1	1	1	12
⊙	2C901180	CONT SENSOR ASSY	1	1	1	1	2
⊙	2C901190	PCB REGISTRATION ASSY	1	1	1	1	11
	2C902070	BASE RUBBER	4	4	4	4	2
	2C902080	SPRING DEV PUSH	1	1	1	1	2
	2C902100	MOUNT REAR COVER	1	1	1	1	2
	2C902110	MOUNT FRONT COVER	1	1	1	1	2
	2C902120	PANEL FRONT	1	1	1	1	2
	2C902130	MOUNT CONT PCB	1	1	1	1	2
	2C902140	HINGE FRONT COVER	1	1	1	1	1
	2C902150	MOUNT CONT LEVER	1	1	1	1	2
	2C902160	RAIL DLP	1	1	1	1	2
⊙	2C902170	LEVER DEV PUSH	1	1	1	1	2
⊙	2C902180	FILM BASE	1	1	1	1	2
	2C902200	RAIL CLEANING	1	1	1	1	2
	2C902230	FILM BASE L	2	2	2	2	2
	2C902240	FILM BASE B	1	1	1	1	2
	2C902260	GROUND PLATE FRAME	1	1	1	1	2
	2C902270	SPACER BASE	1	1	1	1	2
	2C902280	HOLDER PULLEY	2	2	2	2	2
	2C902510	GUIDE A CONT.	1	1			2
⊙	2C902520	COLLAR LEVER CONT.	1	1	1	1	2
⊙	2C902540	LEVER LOCK CONT.	1	1	1	1	2
	2C902560	GUIDE B CONT.	1		1	1	2
⊙	2C902590	SPRING DEV PUSH F	1	1	1	1	2
⊙	2C904010	FRONT RIGHT COVER	1	1	1	1	1
⊙	2C904030	TRAY EXIT (1/2)	1	1	1	1	1
⊙	2C904041	RIGHT COVER	1	1	1	1	1
⊙	2C904050	LEFT COVER	1	1	1	1	7
⊙	2C904060	LEFT LOW COVER	1	1	1	1	1
⊙	2C904070	UPPER FRONT COVER	1	1	1	1	1
⊙	2C904080	FRONT SIDE COVER UP	1	1	1	1	1
⊙	2C904090	FRONT TOP COVER	1	1	1	1	1
⊙	2C904100	RIGHT TOP COVER	1	1	1	1	1
⊙	2C904110	LEFT TOP COVER	1	1	1	1	1
⊙	2C904120	REAR TOP COVER	1	1	1	1	1
⊙	2C904130	FRONT SIDE COVER MID	1	1	1	1	1
⊙	2C904140	FRONT SIDE COVER LOW	1	1	1	1	1
⊙	2C904150	INNER REAR COVER	1	1	1	1	1
⊙	2C904160	INNER LEFT COVER	1	1	1	1	1
⊙	2C904170	REAR COVER	1	1	1	1	1

2C9-2/2FX

SP	Part.No.	Description	Quality				Fig.No.
			110V	120V	230V	240V	
⊙	2C904180	LEFT FRONT COVER	1	1	1	1	1
⊙	2C904190	LEFT REAR COVER	1	1	1	1	1
⊙	2C904200	LEFT MIDDLE COVER	1	1	1	1	1
	2C904210	STOPPER LEFT COVER F	1	1	1	1	7
	2C904220	STOPPER LEFT COVER R	1	1	1	1	7
	2C904230	STRAP LEFT COVER A	1	1	1	1	7
	2C904240	STRAP LEFT COVER B	1	1	1	1	7
	2C904250	SHAFT HOOK	1	1	1	1	7
	2C904260	HOOK LEFT COVER F	1	1	1	1	7
	2C904270	HOOK LEFT COVER R	1	1	1	1	7
	2C904280	JUNCTION PLATE HOOK	1	1	1	1	7
	2C904290	PLATE FRONT COVER	1	1	1	1	1
	2C904300	ARM INTERLOCK SW	1	1	1	1	12
	2C904310	MOUNT INTERLOCK SW	1	1	1	1	12
	2C904340	SPRING LEFT INTERLOCK	1	1	1	1	12
	2C904350	SPRING LEFT HOOK	1	1	1	1	7
	2C904360	STRAP LEFT COVER C	1	1	1	1	6
⊙	2C904370	INNER FRONT COVER	1	1	1	1	1
	2C904390	PLATE LEFT SW	1	1	1	1	7
	2C904410	COVER DSUB	1	1	1	1	1
	2C904420	PIN STRAP	2	2	2	2	7
	2C904430	PLATE LEFT HOOK	1	1	1	1	7
	2C904440	SPRING LEFT COVER	1	1	1	1	7
⊙	2C904460	COVER FRONT STRAP	1	1	1	1	7
⊙	2C904470	FRONT LEFT COVER(K)	1	1	1	1	1
⊙	2C904480	FILM FRONT COVER	1	1	1	1	1
	2C904490	PLATE FRONT STRAP	1	1	1	1	6
⊙	2C904500	PIN LEFT COVER	1	1	1	1	7
	2C904510	SPONGE COVER	1	1	1	1	1
	2C905070	LABEL CONT SET	1	1	1	1	2
⊙	2C905080	LABEL CONVEYING JAM	1	1	1	1	1
⊙	2C905090	LABEL HIGH TEMP	1	1	1	1	7
⊙	2C905100	LABEL RADIATION		1			1
	2C905110	LABEL DRUM CAUTION	1	1	1	1	2
⊙	2C905160	LABEL GLASS CAUTION	1	1	1	1	8
⊙	2C905170	LABEL BYPASS TABLE	1	1	1	1	7
	2C905180	LABEL ERROR CODE J	1	1	1	1	1
	2C905200	LABEL CASSETTE LGR	1	1	1	1	3
⊙	2C905220	LABEL LEFT COVER	1	1	1	1	1
⊙	2C905230	SHEET CASSETTE SIZE(C)	1	1	1	1	3
⊙	2C905240	SHEET CASSETTE SIZE(I)	1	1	1	1	3

• Parts with "⊙" indicates the spare parts.

SP	Part.No.	Description	Quality				Fig.No.
			110V	120V	230V	240V	
⊙	2C906010	COVER BYPASS	1	1	1	1	6
⊙	2C906020	TABLE BYPASS	1	1	1	1	6
⊙	2C906030	FRONT CURSOR BYPASS	1	1	1	1	6
⊙	2C906040	REAR CURSOR BYPASS	1	1	1	1	6
⊙	2C906050	BYPASS SUB TABLE A	1	1	1	1	6
⊙	2C906060	BYPASS SUB TABLE B	1	1	1	1	6
⊙	2C906080	GEAR 18 BYPASS	1	1	1	1	6
	2C906090	TERMINAL PAPER SIZE	1	1	1	1	6
	2C906100	LIFT PLATE BYPASS	1	1	1	1	6
	2C906110	SPRING BYPASS LIFT	1	1	1	1	6
⊙	2C906120	SHEET BYPASS LIFT	1	1	1	1	6
⊙	2C906130	STOPPER BYPASS	1	1	1	1	6
	2C906170	SHAFT BYPASS	1	1	1	1	6
⊙	2C906190	CAM BYPASS	1	1	1	1	6
⊙	2C906200	CLUTCH BYPASS FEED	1	1	1	1	6
	2C906210	BYPASS PAPER GUIDE F	1	1	1	1	6
	2C906220	BYPASS PAPER GUIDE R	1	1	1	1	6
	2C906240	MOUNT LIFT PLATE	1	1	1	1	6
	2C906250	GROUND PLATE BYPASS	1	1	1	1	6
	2C906280	GROUND PLATE LIFT	1	1	1	1	6
	2C906290	SHEET BYPASS GUIDE	2	2	2	2	6
⊙	2C906300	SEAL BYPASS GUIDE	2	2	2	2	6
	2C906310	SEAL BYPASS LIFT	2	2	2	2	6
	2C907010	CASSETTE	1	1	1	1	3
	2C907020	BOTTOM CASSETTE	1	1	1	1	3
⊙	2C907030	REAR CURSOR C	1	1	1	1	3
⊙	2C907040	FRONT CURSOR C	1	1	1	1	3
	2C907050	PLATE SIDE SW	1	1	1	1	3
	2C907060	PLATE SIZE DETECTION	1	1	1	1	5
	2C907070	LEVER INDICATOR	1	1	1	1	3
	2C907080	LEFT RAIL CASSETTE	1	1	1	1	5
⊙	2C907090	SPRING SIDE SW	1	1	1	1	3
⊙	2C907100	STOPPER CASSETTE	1	1	1	1	5
	2C907110	MARKER INDICATOR	1	1	1	1	3
⊙	2C907120	ACTUATOR EMPTY	1	1	1	1	5
⊙	2C907130	GEAR Z15 REGIST	1	1	1	1	5
⊙	2C907140	PAD CASSETTE	1	1	1	1	3
⊙	2C907150	SPRING BOTTOM	2	2	2	2	3
	2C907160	RIGHT GUIDE REGIST	1	1	1	1	5
⊙	2C907170	ACTUATOR REGIST	1	1	1	1	5
	2C907180	RIGHT ROLL REGIST	1	1	1	1	5

SP	Part.No.	Description	Quality				Fig.No.
			110V	120V	230V	240V	
⊙	2C907190	RIGHT CURSOR A	1	1	1	1	3
	2C907200	STOPPER ARM	1	1	1	1	3
	2C907210	SHAFT PAPER FEED	1	1	1	1	5
	2C907230	SHAFT PICK UP B	1	1	1	1	5
	2C907240	PLATE PICK UP B	1	1	1	1	5
	2C907250	HOLDER RETARD	1	1	1	1	5
⊙	2C907260	SLIDER RAIL	2	2	2	2	5
	2C907270	LEVER PICK UP	1	1	1	1	5
⊙	2C907280	TORQUE LIMITER 340	1	1	1	1	5
⊙	2C907290	SPRING REGIST B	1	1	1	1	5
	2C907300	SHAFT RETARD	1	1	1	1	5
	2C907320	SPRING RETARD	1	1	1	1	5
	2C907340	SPRING PICK UP	2	2	2	2	5
	2C907350	SPRING LEVER	1	1	1	1	5
	2C907360	SPRING CURSOR R	2	2	2	2	3
⊙	2C907370	MARKER CASSETTE	1	1	1	1	3
	2C907380	TURN PLATE CASSETTE	1	1	1	1	3
⊙	2C907390	LEVER CURSOR C	1	1	1	1	3
	2C907400	HOLDER PULLEY A	1	1	1	1	5
	2C907410	PULLEY GUIDE A	1	1	1	1	5
	2C907420	HOLDER FEED SHAFT	1	1	1	1	5
⊙	2C907430	BUSH PAPER FEED C	2	2	2	2	5
	2C907440	RIGHT MOUNT REGIST	1	1	1	1	5
	2C907470	GROUND PLATE REG R	1	1	1	1	5
	2C907480	HOLDER SENSOR	1	1	1	1	5
	2C907490	STOPPER INDICATOR	1	1	1	1	3
	2C907500	GROUND PLATE BOTTOM	1	1	1	1	3
	2C907510	GROUND PLATE CASS	1	1	1	1	5
	2C907520	PLATE HEATER J	1	1	1	1	16
	2C907530	FILM REGIST R	2	2	2	2	5
	2C907540	GROUND PLATE REG F	1	1	1	1	5
	2C907550	LID CASSETTE A	1	1	1	1	3
	2C907560	LID CASSETTE B	1	1	1	1	3
	2C907570	LID CASSETTE C	1	1	1	1	3
	2C907580	FILM BASE R/B	2	2	2	2	5
⊙	2C907590	HOLDER RIGHT CURSOR	1	1	1	1	3
⊙	2C907600	PIN CURSOR C	1	1	1	1	3
	2C907610	SHEET TONER TANK	1	1	1	1	5
⊙	2C907620	SPRING LEVER F	1	1	1	1	3
	2C907640	STOPPER PLATE SIZE	1	1	1	1	5
	2C910040	GRID	1	1	1	1	9

* Parts with "⊙" indicates the spare parts.

SP	Part.No.	Description	Quality				Fig.No.
			110V	120V	230V	240V	
⊙	2C912090	LAMP SCANNER YG	1	1	1	1	8
	2C912100	MIRROR FRAME A	1	1	1	1	8
	2C912110	REFLECTOR SCANNER	1	1	1	1	8
	2C912120	MIRROR FRAME B	1	1	1	1	8
	2C912130	ADJUSTING PLATE B	1	1	1	1	8
	2C912140	MOUNT BASE DF HINGE LEFT	2	2	2	2	8
	2C912150	RETAINER WIRE	2	2	2	2	8
	2C912160	GUIDE FFC B	1	1	1	1	8
	2C912180	FILM FRAME A	1	1	1	1	8
	2C912190	STANDARD PLATE SHADING	1	1	1	1	8
	2C912200	LEFT SIZE INDICATOR	1	1	1	1	8
	2C912210	REAR SIZE INDICATOR(M)	1	1	1	1	8
	2C912220	MOUNT PI	1	1	1	1	8
	2C912230	HOLDER FFC A	1	1	1	1	8
	2C912250	CONTACT GLASS	1	1	1	1	8
⊙	2C912260	BELT SCANNER	1	1	1	1	8
	2C912270	LOWER SEAL SCANNER	2	2	2	2	8
⊙	2C912280	CONTACT GLASS ADF	1	1	1	1	8
	2C912290	SPRING SCANNER TENSION	2	2	2	2	8
	2C912300	MOTOR PLATE SCANNER	1	1	1	1	8
⊙	2C912310	GEAR Z18/39	1	1	1	1	8
⊙	2C912320	GEAR Z36	1	1	1	1	8
	2C912330	SHAFT MOTOR DRIVE	1	1	1	1	8
⊙	2C912340	DRUM PULLEY	2	2	2	2	8
	2C912350	FRONT WIRE SCANNER	1	1	1	1	8
	2C912360	REAR WIRE SCANNER	1	1	1	1	8
⊙	2C912380	MOTOR SCANNER	1	1	1	1	8
⊙	2C912390	MIRROR A	1	1	1	1	8
	2C912400	PIN SCANNER RETAINING	4	4	4	4	8
	2C912410	GROUND PLATE SCANNER	3	3	3	3	8
	2C912420	HOLDER GLASS DF	1	1	1	1	8
	2C912430	LID KMAS	1	1	1	1	1
	2C912440	LABEL SIZE (METRIC)	1	1	1	1	8
	2C912450	LABEL SIZE (INCH)		1			8
	2C912460	REAR SIZE INDICATOR(I)		1			8
	2C912470	PLATE DSUB	1	1	1	1	8
	2C912480	HOLDER CCD WIRE	1	1	1	1	8
	2C912490	MOUNT DSUB	1	1	1	1	8
	2C912580	COVER ISU	1	1	1	1	8
	2C912600	FRONT SIZE INDICATOR	1	1	1	1	8
	2C912610	MOUNT RELEASE SWITCH	1	1	1	1	8

2C9-2/2FX

SP	Part.No.	Description	Quality				Fig.No.
			110V	120V	230V	240V	
	2C912620	GUIDE RELEASE SWITCH	1	1	1	1	8
	2C912630	STOPPER RELEASE SWITCH	1	1	1	1	14
	2C912640	SHAFT RELEASE SWITCH	1	1	1	1	8
	2C912650	SPRING RELEASE SWITCH	1	1	1	1	8
	2C912660	GUIDE CCD WIRE	1	1	1	1	8
	2C912670	SHIELD SCANNER FRAME	4	4	4	4	8
⊙	2C912680	PULLEY SCANNER	6	6	6	6	8
	2C912690	GROUND PLATE SCANNER B	1	1	1	1	8
⊙	2C912700	SPONGE ORIGINAL SIZE	1	1	1	1	8
	2C912710	SHIELD SCANNER FRAME B	1	1	1	1	8
	2C912720	SHIELD BASE	1	1	1	1	8
	2C914080	REAR COVER DLP	1	1	1	1	9
	2C914280	GEAR Z20H B	1	1	1	1	9
⊙	2C916020	ROLLER REGIST LEFT	1	1	1	1	4
	2C916030	BASE CONVEYING	1	1	1	1	4
⊙	2C916040	FILM REGIST GUIDE	1	1	1	1	4
⊙	2C916060	LEVER CONVEYING FRONT	1	1	1	1	4
⊙	2C916070	LEVER CONVEYING REAR	1	1	1	1	4
⊙	2C916080	STOPPER BUSH REG	2	2	2	2	4
	2C916090	GUIDE CONVEYING	1	1	1	1	4
	2C916100	SPRING REGIST F	1	1	1	1	4
	2C916120	SPRING CONVEYING BASE	1	1	1	1	4
	2C916130	GROUND PLATE REG	1	1	1	1	4
	2C916140	GROUND PLATE CONVEYING	1	1	1	1	4
	2C916150	PIN CONVEYING HOOK	1	1	1	1	12
	2C916160	SHAFT CONVEYING	1	1	1	1	4
	2C916170	GUIDE FEED A	1	1	1	1	4
⊙	2C916180	GEAR Z15 REGIST	1	1	1	1	4
	2C916190	SPRING REGIST R	1	1	1	1	4
	2C916200	LEVER TRANS GUIDE	2	2	2	2	4
	2C916220	REINFORCEMENT CONVEYING	1	1	1	1	4
	2C916230	SHAFT CONVEYING LEVER	1	1	1	1	4
	2C916240	FILM REGIST GUIDE R	1	1	1	1	4
	2C916250	COLLAR REGIST	2	2	2	2	4
⊙	2C916260	BUSH REGIST	2	2	2	2	4
	2C916270	SPACER REG F	1	1	1	1	4
	2C916280	SPACER REG T0.5	4	4	4	4	4
	2C916290	FILM CONV BASE	1	1	1	1	4
⊙	2C917010	ROLLER TRANSFER	1	1	1	1	4
⊙	2C917020	GEAR TRANSFER	1	1	1	1	4
	2C917030	GUIDE LEFT TRANS FRONT	1	1	1	1	4

• Parts with "⊙" indicates the spare parts.

SP	Part.No.	Description	Quality				Fig.No.
			110V	120V	230V	240V	
	2C917040	TERMINAL PLATE TRANS	1	1	1	1	4
	2C917050	REINFORCEMENT TRANS GUIDE	1	1	1	1	4
	2C917060	SPRING TRANS F	1	1	1	1	4
⊙	2C917070	HOUSING STA ELIMINATION	1	1	1	1	4
⊙	2C917080	PLATE STA ELIMINATION	1	1	1	1	4
	2C917090	TERMINAL STA ELIMINATION	1	1	1	1	4
⊙	2C917100	BUSH TRANSFER	1	1	1	1	4
⊙	2C917110	COLLAR TRANS	2	2	2	2	4
	2C917120	SPRING TRANS R	1	1	1	1	4
	2C917140	GUIDE TRANS RIGHT	1	1	1	1	5
	2C917150	SPRING GUIDE TRANS	2	2	2	2	4
	2C917160	BUSH TRANS GUIDE F	1	1	1	1	4
	2C917170	BUSH TRANS GUIDE R	1	1	1	1	4
	2C917180	BUSH TRANS ROLL F	1	1	1	1	4
	2C917190	FILM RIGHT TRANS GUIDE	1	1	1	1	5
	2C917200	SPACER TRANS ROLL	4	4	4	4	4
	2C917210	SPACER GUIDE LEFT TRANS	4	4	4	4	4
	2C918010	BLADE CLEANING	1	1	1	1	9
	2C918040	LOWER SEAL CLEANING	1	1	1	1	9
	2C918050	FRONT COVER CLEANING	1	1	1	1	9
	2C918150	TANK DISPOSAL	1	1	1	1	1
	2C918170	CAP TANK DISPOSAL	1	1	1	1	1
	2C918340	HOLDER CLAW	3	3	3	3	9
	2C918350	DETECTION PLATE	1	1	1	1	12
	2C918360	SPRING DETECTION	1	1	1	1	12
	2C918370	CLAW SEPARATION	3	3	3	3	9
	2C918400	HOLDER SENSOR B	1	1	1	1	12
	2C920010	RIGHT FRAME FUSER	1	1	1	1	10
	2C920020	LEFT FRAME FUSER	1	1	1	1	10
	2C920030	REAR GUIDE FUSER	1	1	1	1	10
	2C920040	FRONT GUIDE FUSER	1	1	1	1	10
⊙	2C920050	ROLLER HEAT	1	1	1	1	10
⊙	2C920060	ROLLER PRESS	1	1	1	1	10
	2C920110	FRONT PRESSING PLATE	1	1	1	1	10
	2C920120	REAR PRESSING PLATE	1	1	1	1	10
	2C920130	SPRING PRESSURE	2	2	2	2	10
	2C920140	PLATE HEATER FUSER	1	1	1	1	10
⊙	2C920150	FRONT BUSH HEAT ROLLER	1	1	1	1	10
⊙	2C920160	REAR BUSH HEAT ROLLER	1	1	1	1	10
⊙	2C920170	GEAR Z38 HEAT ROLLER	1	1	1	1	10
⊙	2C920180	GEAR FUSER Z28	1	1	1	1	10

SP	Part.No.	Description	Quality				Fig.No.
			110V	120V	230V	240V	
⊙	2C920190	SPRING SEPARATOR	5	5	5	5	10
	2C920200	GROUND PLATE PRESS	1	1	1	1	10
⊙	2C920230	HEATER M120 FUSER	1	1			10
⊙	2C920240	HEATER S120 FUSER	1	1			10
⊙	2C920250	HEATER M230 FUSER			1	1	10
⊙	2C920260	HEATER S230 FUSER			1	1	10
⊙	2C920310	THERMISTOR FUSER	1	1	1	1	10
	2C920320	SEAL DISCHAGER	1	1	1	1	10
⊙	2C920330	BEARING PRESSURE	2	2	2	2	10
⊙	2C920340	THERMOCUT 180 FUSER	1	1	1	1	10
⊙	2C921010	ROLLER EXIT INNER	1	1	1	1	7
⊙	2C921020	ROLLER FEED SHIFT	1	1	1	1	7
⊙	2C921040	PULLEY FEED SHIFT	4	4	4	4	7
	2C921050	GUIDE SHIFT	1	1	1	1	7
	2C921061	GUIDE SEPARATE	1	1	1	1	7
	2C921071	HOUSING EXIT UPPER	1	1	1	1	7
	2C921080	HOUSING EXIT LOWER	1	1	1	1	7
	2C921091	GUIDE EXIT LOWER	1	1	1	1	7
⊙	2C921100	ACTUATOR EXIT INNER	1	1	1	1	7
⊙	2C921110	ACTUATOR EXIT LEFT	1	1	1	1	7
⊙	2C921120	GEAR 23 EXIT	1	1	1	1	7
	2C921150	ARM SHIFT	1	1	1	1	7
⊙	2C921160	ARM SEPARATE	1	1	1	1	7
	2C921180	ARM LINK	1	1	1	1	7
	2C921190	SPRING PULLEY INNER	2	2	2	2	7
	2C921200	SPRING PULLEY FEED SHIFT	4	4	4	4	7
	2C921221	SPRING GUIDE DU	2	2	2	2	7
	2C921231	GUIDE DU	1	1	1	1	7
	2C921240	ARM SHIFT B	1	1	1	1	7
	2C921260	PLATE EARTH EXIT 2	1	1	1	1	7
	2C921270	ARM SEPARATE B	1	1	1	1	7
	2C921280	SPRING SEPARATE	1	1	1	1	7
	2C921290	SPRING LINK	1	1	1	1	7
	2C921301	BRACKET EXIT	1	1	1	1	7
	2C921310	PLATE EARTH EXIT B	1	1	1	1	7
	2C921330	SPRING ACTUATOR INNER	1	1	1	1	7
⊙	2C921340	BELT EXIT	2	2	2	2	7,15
⊙	2C921350	PULLEY EXIT	2	2	2	2	7
⊙	2C921360	PULLEY EJECT	4	4	4	4	7
	2C921370	STOPPER SE	1	1	1	1	7
	2C921380	SPRING PULLEY EJECT	2	2	2	2	7

* Parts with "⊙" indicates the spare parts.

SP	Part.No.	Description	Quality				Fig.No.
			110V	120V	230V	240V	
	2C921390	PLATE EXIT HOLDER	1	1	1	1	7
	2C921400	SHOULDER SCREW EXIT	2	2	2	2	7
	2C922010	MOUNT DRIVE UNIT	1	1	1	1	11
⊙	2C922020	GEAR 122	1	1	1	1	11
⊙	2C922030	GEAR 88/34	1	1	1	1	11
⊙	2C922040	GEAR 50	1	1	1	1	11
⊙	2C922050	GEAR 40	4	4	4	4	11
⊙	2C922060	POSITIONING BUSH DRUM	1	1	1	1	11
⊙	2C922070	GEAR 30/23	1	1	1	1	11
⊙	2C922080	GEAR 60	1	1	1	1	11
⊙	2C922100	GEAR 25 DPX	1	1	1	1	11
⊙	2C922110	GEAR 32 DPX	1	1	1	1	11
	2C922130	MOUNT CONT DRIVE	1	1	1	1	11
⊙	2C922140	GEAR 25 DEV	1	1	1	1	11
⊙	2C922150	GEAR 26 DEV	1	1	1	1	11
⊙	2C922160	SHAFT DPX DRIVE	1	1	1	1	11
⊙	2C922170	COUPLING CONT P	1	1	1	1	11
⊙	2C922180	COUPLING CONT S	1	1	1	1	11
⊙	2C922190	COUPLING DRUM	1	1	1	1	11
⊙	2C922200	GEAR 43/20	1	1	1	1	11
⊙	2C922210	GEAR 20	1	1	1	1	11
⊙	2C922220	GEAR 25	1	1	1	1	11
⊙	2C922230	GEAR 29 FIX JOINT	1	1	1	1	11
	2C922240	SPRING FIX JOINT	1	1	1	1	11
	2C922250	SPRING DRUM COUPLING	1	1	1	1	11
	2C922260	SPRING CONT P	1	1	1	1	11
	2C922270	SPRING CONT S	1	1	1	1	11
	2C922280	MOUNT HV PCB	1	1	1	1	11
	2C922290	HOLDER GEAR	1	1	1	1	11
⊙	2C922300	GEAR 40 FIXJOINT	1	1	1	1	11
⊙	2C922330	GEAR 30 PF	1	1	1	1	11
⊙	2C922340	GEAR 31	1	1	1	1	11
⊙	2C922350	GEAR 51 REG	1	1	1	1	11
⊙	2C922360	GEAR 25 PF	1	1	1	1	11
	2C922370	MOUNT REG MOTOR	1	1	1	1	11
	2C923010	UPPER DUCT	1	1	1	1	11
	2C923020	LOWER DUCT	1	1	1	1	11
	2C923030	FILM COOLING	1	1	1	1	11
⊙	2C925030	KEY OPERATION 10	1	1	1	1	13
⊙	2C925040	KEY SAVER	1	1	1	1	13
⊙	2C925050	KEY PROGRAM	1	1	1	1	13

2C9-2/2FX

SP	Part.No.	Description	Quality				Fig.No.
			110V	120V	230V	240V	
⊙	2C925060	KEY EXPOSURE	1	1	1	1	13
⊙	2C925070	KEY ZOOM	1	1	1	1	13
⊙	2C925080	KEY SIZE	2	2	2	2	13
⊙	2C925100	COVER OPERATION E		1	1	1	13
⊙	2C925120	LEFT OPE SHEET I		1	1	1	13
	2C925150	RIGHT DUST SHIELD	1	1	1	1	13
	2C925160	LEFT DUST SHIELD	1	1	1	1	13
	2C925170	CENTER DUST SHIELD	1	1	1	1	13
	2C925180	RETAINER OPERATION	1	1	1	1	13
	2C925190	SHEET OPERATION PCB	1	1	1	1	2
	2C925200	MOUNT OPERATION R	1	1	1	1	13
	2C925210	SPACER OPE PCB	1	1	1	1	13
⊙	2C925220	COVER OPERATION(RS)	1				13
⊙	2C925240	LEFT OPE SHEET (RS)	1				13
	2C925260	CENTER OPE SHEET I		1			13
	2C925270	CENTER OPE SHEET M			1	1	13
	2C925280	CENTER OPE SHEET(RS)	1				13
⊙	2C925320	LENS OPERATION COVER	11	11	11	11	13
⊙	2C925330	CENTER OPE COVER	1	1	1	1	13
	2C926010	BASE TERMINAL TRANSFER	1	1	1	1	2
	2C926020	BASE TERMINAL MAIN	1	1	1	1	2
	2C926030	TERMINAL DLP	1	1	1	1	2
	2C926040	TERMINAL TRANSFER	1	1	1	1	2
	2C926050	TERMINAL SEPARATION	1	1	1	1	2
	2C926060	TERMINAL MAIN	1	1	1	1	2
	2C926070	HOLDER INTERLOCK SW	1	1	1	1	12
	2C926080	GROUND PLATE CONVEYING	1	1	1	1	2
	2C926100	TERMINAL FUSER	1	1	1	1	2
	2C926110	GROUND PLATE EXIT	1	1	1	1	2
	2C926120	GROUND PLATE FUSER	1	1	1	1	2
	2C926130	SHIELD RIGHT COVER	1	1	1	1	1
	2C926140	SHIELD UPPER LEFT	1	1	1	1	2
	2C926150	SHIELD UPPER LEFT B	1	1	1	1	2
	2C926160	SHIELD CCD WIRE	1	1	1	1	12
	2C926500	SHIELD MAIN	1	1	1	1	12
	2C926510	MOUNT POWER SOURCE	1	1	1	1	12
	2C926520	PLATE INLET	1	1	1	1	12
⊙	2C927010	MOTOR MAIN	1	1	1	1	11
⊙	2C927020	MOTOR EJECT	1	1	1	1	11
⊙	2C927050	SOLENOID BYPASS	1	1	1	1	6
⊙	2C927070	FAN COOLING 80-25	2	2	2	2	11

• Parts with "⊙" indicates the spare parts.

SP	Part.No.	Description	Quality				Fig.No.
			110V	120V	230V	240V	
⊙	2C927090	SENSOR ORIGINAL	1	1	1	1	8
⊙	2C927140	SWITCH CONTAINER	1	1	1	1	2
⊙	2C927170	SWITCH INTERLOCK L	1	1	1	1	12
⊙	2C927180	SWITCH INTERLOCK F	1	1	1	1	12
⊙	2C927190	CLUTCH FEED	1	1	1	1	11
⊙	2C927210	SENSOR 248NL1	4	4	4	4	5,6,8,15
⊙	2C927220	MOTOR REGISTRATION	1	1	1	1	11
	2C927230	CORE SFT-72SNB-026K	1	1	1	1	12
	2C927250	GASKET SHIELD 8X10X45			1	1	12
	2C927510	WIRE ENGINE	1	1	1	1	12
	2C927520	WIRE CASSETTE PCB	1	1	1	1	5
	2C927530	WIRE EJECT	1	1	1	1	7
	2C927540	WIRE DP	1	1	1	1	8
	2C927550	WIRE SCANNER PI	1	1	1	1	8
	2C927560	WIRE ORIGINAL SIZE	1	1	1	1	8
⊙	2C927580	FFC INVERTER	1	1	1	1	8
	2C927600	WIRE FUSER	1	1	1	1	12
	2C927610	WIRE DESK POWER	1	1	1	1	12
	2C927620	WIRE MPF	1	1	1	1	6
⊙	2C927630	FFC CCD	1	1	1	1	8
	2C927640	WIRE PANEL	1	1	1	1	13
	2C927650	WIRE LASER	1	1	1	1	12
	2C927660	WIRE DESK	1	1	1	1	12
	2C927670	WIRE CASSETTE SW	1	1	1	1	5
	2C927680	WIRE FRONT SW	1	1	1	1	12
	2C927690	WIRE FUSER UNIT	1	1	1	1	10
⊙	2C927740	FFC HVU	1	1	1	1	12
	2C927750	WIRE CASSETTE PE	1	1	1	1	5
	2C927760	WIRE MAIN MOTOR	1	1	1	1	11
	2C927780	WIRE DEHUMIDIFIER	1	1	1	1	16
	2C927790	WIRE UPPER LEFT	1	1	1	1	2
⊙	2C928040	PCB LAMP INVERTER	1	1	1	1	8
⊙	2C928050	PCB HIGH VOLTAGE	1	1	1	1	12
⊙	2C928080	PCB LVU 100	1	1			12
⊙	2C928090	PCB LVU 200			1	1	12
⊙	2C960100	MOUNT KEY COUNTER	1	1	1	1	16
⊙	2C960110	WIRE KEY COUNTER	1	1	1	1	16
⊙	2C968132	PCB FLASH DIMM ASSY	1	1	1	1	16
⊙	2C968182	PCB ENGINE ASSY SP	1	1	1	1	12
⊙	2C968190	PCB MAIN ASSY SP	1	1	1	1	12
⊙	2C982010	SET MK-410	1	1	1	1	9

SP	Part.No.	Description	Quality				Fig.No.
			110V	120V	230V	240V	
⊙	2C993010	PARTS,CT-410,SP	1	1	1	1	3
⊙	2C993020	PARTS,MC-410,SP	1	1	1	1	9
⊙	2C993030	PARTS,DV-410,SP	1	1	1	1	9
⊙	2C993050	PARTS,FK-410(A),SP	1	1			10
⊙	2C993060	PARTS,FK-410(E),SP			1	1	10
⊙	2C993081	PARTS,OPE ASS'Y(I)SP		1			13
⊙	2C993090	PARTS,LSU ASS'Y,SP	1	1	1	1	12
⊙	2C993101	PARTS,OPE ASS'Y(M)SP	1		1	1	13
⊙	2C993130	PARTS,BYPASS PULLEY,SP	1	1	1	1	6
⊙	2C993140	PARTS,BYPASS PAD,SP	1	1	1	1	6
⊙	2C993170	PARTS,CONTACT GLASS,M(SP)	1		1	1	8
⊙	2C993180	PARTS,CONTACT GLASS,I(SP)		1			8
⊙	2C993190	PARTS,DEH.ASS'Y120,SP	1	1			16
⊙	2C993200	PARTS,DEH.ASS'Y240,SP			1	1	16
⊙	2C993210	PARTS,REGIST CLEANER,ASSY	1	1	1	1	5
	2DC12230	SLIDER SCANNER	8	8	8	8	8
⊙	2DC25050	KEY PRINT	1	1	1	1	13
⊙	2DC25060	KEY STOP	1	1	1	1	13
⊙	2DC25070	KEY RESET	1	1	1	1	13
⊙	2DC27180	SWITCH PI	1	1	1	1	8
⊙	2FX04010	FRONT RIGHT COVER		1	1	1	1
⊙	2FX68010	PCB ENGINE ASSY SP		1	1	1	12
⊙	29807100	GEAR 16,BYPASS	2	2	2	2	5
⊙	29812291	CUSHION,CONTACT GLASS	9	9	9	9	8
⊙	3CY07080	BUSHING 6	8	8	8	8	5,7,11
	3HY07010	FRAME DUPLEX	1	1	1	1	15
⊙	3HY07020	ROLLER DUPLEX A	1	1	1	1	15
⊙	3HY07030	ROLLER DUPLEX B	1	1	1	1	15
⊙	3HY07040	PULLEY 26-6 DUPLEX	1	1	1	1	15
⊙	3HY07050	PULLEY 26-8 DUPLEX	1	1	1	1	15
	3HY07060	JUNCTION PLATE DUPLEX	1	1	1	1	15
	3HY07070	SPRING JUNCTION DUPLEX	1	1	1	1	15
⊙	3HY07090	GEAR 21 DUPLEX	1	1	1	1	15
⊙	3HY07100	PULLEY IDLE DUPLEX	1	1	1	1	15
	3HY07110	RETAINER DUPLEX	1	1	1	1	15
⊙	3HY07120	PULLEY 15 DUPLEX	8	8	8	8	15
	3HY07130	SHAFT 4 DUPLEX	4	4	4	4	15
	3HY07140	HOLDER DUPLEX SPRING	4	4	4	4	15
⊙	3HY07150	BUSHING DUPLEX ROLLER	8	8	8	8	15
	3HY07160	SPRING DUPLEX PULLEY	8	8	8	8	15
⊙	3HY07170	ACTUATOR DUPLEX	1	1	1	1	15

• Parts with "⊙" indicates the spare parts.

SP	Part.No.	Description	Quality				Fig.No.
			110V	120V	230V	240V	
	3HY07180	RETAINER ACTUATOR	1	1	1	1	15
	3HY07190	PROTECTING PLATE WIRE	1	1	1	1	15
	3HY07200	GROUND PLATE DUPLEX	1	1	1	1	15
	3HY07210	LID DUPLEX	1	1	1	1	15
	3HY07220	PLATE LOCK DUPLEX	1	1	1	1	15
	3HY27010	WIRE DUPLEX	1	1	1	1	15
⊙	3HY27020	CLUTCH DU	1	1	1	1	15
	33910230	PIN CHARGER	1	1	1	1	9
⊙	34821210	STATIC ELIMINATOR B,EJECT	1	1	1	1	7
⊙	34907141	GEAR 18,CASSETTE	1	1	1	1	3
	35912210	SPRING,MIRROR HOLDER	6	6	6	6	8
	35968110	STOPPER WIRE ASS'Y SP	2	2	2	2	16
	41525016	SOCKET,KEY COUNTER	2	2	2	2	16
	41529210	SOCKET ASS'Y,KEY COUNTER	1	1	1	1	16
	60804120	MAGNET CATCH	1	1	1	1	1
	60904280	ORIGINAL POCKET	1	1	1	1	14
	65027600	POWER CORD 110	1				12
	66060030	RETAINER,KEY COUNTER	1	1	1	1	16
	66060040	MOUNT,KEY COUNTER	1	1	1	1	16
⊙	76508130	SPRING BELT GUIDE ROLLER	1	1	1	1	3
⊙	82142540	KEY COUNTER	1	1	1	1	16
⊙	B0004350	ROUND HEAD SCREW M4X35	1	1	1	1	16
⊙	B2303060	COUNTER-SUNK HEAD SCREW BFHM3X6 (B	2	2	2	2	16
⊙	B4304060	TRIPLE SCREW M4X6 (BLACK)	4	4	4	4	16
	B8013120	BINDING TAP-TITE P SCREW M3X12	2	2	2	2	14
	B8014160	BINDING TAP-TITE P SCREW M4X16	6	6	6	6	14
⊙	C2303000	NUT BNM3 (BLACK)	1	1	1	1	16
	J0220040	PLUG EL 4P,ELP-04V	1	1	1	1	16
	M0208000	SPACER,SFS-4S-B1WM(JST)	2	2	2	2	8
⊙	M1658030	FUSE,215008(LITTEL-FUSE)			1	1	12
	M2105740	MINIATURE CLAMP,UAMS-05S-2	4	4	4	4	12
	M2108130	SPACER,KGPS-4S	3	3	3	3	12
	M2109000	WIRE SADDLE,WS-1NS	3	3	3	3	8,12
	M2109020	WIRE SADDLE,WS-2WS	1	1	1	1	12
⊙	M5561000	FUSE,CES6-N1(SOC)	1	1			12
⊙	M6056000	FUSE,19181-T6.3H(WICKMANN)			1	1	12
	M70A5020	CLAMP,FCC-125EM513(TAKEUCHI)	1	1	1	1	12
	M7005030	CLAMP,EMT-5N(TAKEUCHI)	1	1	1	1	12
⊙	SP000360	PUSH SWITCH 03 SN	1	1	1	1	5

CLASSIFICATION OF THE SCREWS IN ILLUSTRATION

<u>REF.</u>	<u>ITEM #</u>	<u>DESCRIPTION</u>
BBB	B1303050	BINDING SCREW BVM3X5 (BLACK)
BBE	B1304060	BINDING SCREW BVM4X6 (BLACK)
BBG	B1304100	BINDING SCREW BVM4X10 (BLACK)
BBR	B1303080	BINDING SCREW BVM3X8 (BLACK)
BHA	B3023060	BINDING TAP TITE S SCREW M3X6
BHI	B3313080	BINDING TAP-TITE SCREW M3X08
BHU	B8013120	BINDING TAP-TITE P SCREW M3X12
BUA	B3314100	BINDING TAP-TITE P BRONZE SCREW M4X10
BUC	B3314120	M4X12 +BINDING TAP-TIGHT P SCREW
FDD	B3324060	BINDING TAP TIGHT SCREW M4X6 (BLACK)
GEA	B9604080	GROUNDING SCREW M4X8 (BRASS,N;)
HCA	B4104060	TRIPLE SCREW M4X6(CHROMIUM)
HCJ	B4104100	TRIPLE SCREW M4X10(CHROMIUM)
HDB	B4343080	TRIPLE TAP-TITE P SCREW M3X08(BLACK)
HDK	B4144100	+TP TAP-TITE P SCREW M4X10(CHROMIUM)
KAL	E0020100	SPRING PIN 2X10
TGB	C4204000	CROWN WASHER TWM4
XBB	C2893140	SHIM 6.2X14X0.25T

KYOCERA MITA EUROPE B.V.

Hoeksteen 40, 2132 MS Hoofddorp,
The Netherlands
Phone: +31.(0)20.654.000
Home page: <http://www.kyoceramita-europe.com>
Email: info@kyoceramita-europe.com

KYOCERA MITA NEDERLAND B.V.

Hoeksteen 40 2132 MS Hoofddorp
The Netherlands
Phone: +31.(0)20.587.7200

KYOCERA MITA (UK) LTD.

8 Beacontree Plaza
Gillette Way,
Reading Berks RG2 0BS, UK
Phone: +44.(0)118.931.1500

KYOCERA MITA ITALIA S.P.A.

Via Verdi 89 / 91 20063 Cernusco sul Naviglio,
Italy
Phone: +39.02.92179.1

S.A. KYOCERA MITA BELGIUM N.V.

Hermesstraat 8A 1930 Zaventem Belgium
Phone: +32.(0)2.720.9270

KYOCERA MITA FRANCE S.A.

Parc Les Algorithmes
Saint Aubin
91194 GIF-SUR-YVETTE
France
Phone: +33.(0)1.6985.2600

KYOCERA MITA ESPAÑA S.A.

Edificio Kyocera, Avda de Manacor N. 2,
Urb. Parque Rozas 28290 Las Rozas,
Madrid, Spain
Phone: +34.(0)91.631.8392

KYOCERA MITA FINLAND OY

Kirvesmiehenkatu 4 00810 Helsinki,
Finland
Phone: +358.(0)9.4780.5200

KYOCERA MITA (SCHWEIZ) AG

Holzliwisen Industriestrasse 28
8604 Volketswil, Switzerland
Phone: +41.(0)1.908.4949

KYOCERA MITA DEUTSCHLAND GMBH

Mollsfeld 12 D-40670 Meerbusch,
Germany
Phone: +49.(0)2159.918.0

KYOCERA MITA GMBH AUSTRIA

Eduard-Kittenberger Gasse 95
1230 Wien, Austria
Phone: +43.(0)1.86338.0

KYOCERA MITA SVENSKA AB

Box 1402 171 27 Solna, Sweden
Phone: +46.(0)8.546.550.00

KYOCERA MITA NORGE

Postboks 150 Oppsal, NO 0619 Oslo
Olaf Helsetsvet 6, NO 0694 Oslo
Phone: +47.(0)22.62.73.00

KYOCERA MITA DANMARK A/S

Hovedkontor: Slotsmarken 11,
DK-2970 Hørsholm, Denmark
Phone: +45.(70)22.3880

KYOCERA MITA PORTUGAL LDA.

Rua do Centro Cultural, no 41 1700-106
Lisbon, Portugal
Phone: +351.(0)21.842.9100

KYOCERA MITA SOUTH AFRICA (PTY) LTD.

527 Kyalami Boulevard,
Kyalami Business Park 1685 Midrand South
Phone: +27.(0)11.466.3290

KYOCERA MITA AMERICA, INC.

Headquarters:

225 Sand Road,
Fairfield, New Jersey 07004-0008,
U.S.A.
Phone: (973) 808-8444

KYOCERA MITA AUSTRALIA PTY. LTD.

Level 3, 6-10 Talavera Road, North Ryde,
N.S.W. 2113 Australia
Phone: (02) 9888-9999

KYOCERA MITA NEW ZEALAND LTD.

1-3 Parkhead Place, Albany
P.O. Box 302 125 NHPC, Auckland,
New Zealand
Phone: (09) 415-4517

KYOCERA MITA (THAILAND) CORP., LTD.

9/209 Ratchada-Prachachem Road,
Bang Sue, Bangkok 10800, Thailand
Phone: (02) 586-0320

KYOCERA MITA SINGAPORE PTE LTD.

121 Genting Lane, 3rd Level,
Singapore 349572
Phone: 67418733

KYOCERA MITA HONG KONG LIMITED

11/F., Mita Centre,
552-566, Castle Peak Road,
Tsuen Wan, New Territories,
Hong Kong
Phone: 24297422

KYOCERA MITA TAIWAN Corporation.

7F-1~2, No.41, Lane 221, Gangchi Rd.
Neihu District, Taipei, Taiwan, 114. R.O.C.
Phone: (02) 87511560

KYOCERA MITA Corporation

2-28, 1-chome, Tamatsukuri, Chuo-ku
Osaka 540-8585, Japan
Phone: (06) 6764-3555
<http://www.kyoceramita.com>

© 2004 KYOCERA MITA Corporation

 is a trademark of Kyocera Corporation

Printed in Holland